

# golf vale

EMAAR SOUTH

---

FLOOR PLANS

EMAAR

# golf vale

EMAAR SOUTH

## 1 BEDROOM-TYPE 1

UNIT: P04, P05, P06, P07, 108, 109, 110, 111, 201, 301, 401, 501, 601, 701, 801, 901, 1001, 1101, 202, 302, 402, 502, 602, 702, 802, 902, 1002, 1102, 208, 308, 408, 508, 608, 708, 808, 908, 1008, 1108, 209, 309, 409, 509, 609, 709, 809, 909, 1009, 1109, 210, 310, 410, 510, 610, 710, 810, 910, 1010, 1110, 211, 311, 411, 511, 611, 711, 811, 911, 1011, 1111

SUITE AREA	57.82	SQM	622.37	SQFT
BALCONY AREA	04.98	SQM	53.60	SQFT
TOTAL AREA	62.80	SQM	675.97	SQFT

UNIT: P13,117,217,317,417,517,617,717,817,917,1017,1117

SUITE AREA	57.46	SQM	618.49	SQFT
BALCONY AREA	04.98	SQM	53.60	SQFT
TOTAL AREA	62.44	SQM	672.10	SQFT

UNIT: 220,320,420,520,620,720,820,920,1020,1120

SUITE AREA	57.62	SQM	620.43	SQFT
BALCONY AREA	04.98	SQM	53.60	SQFT
TOTAL AREA	62.62	SQM	674.04	SQFT



KEY SECTION

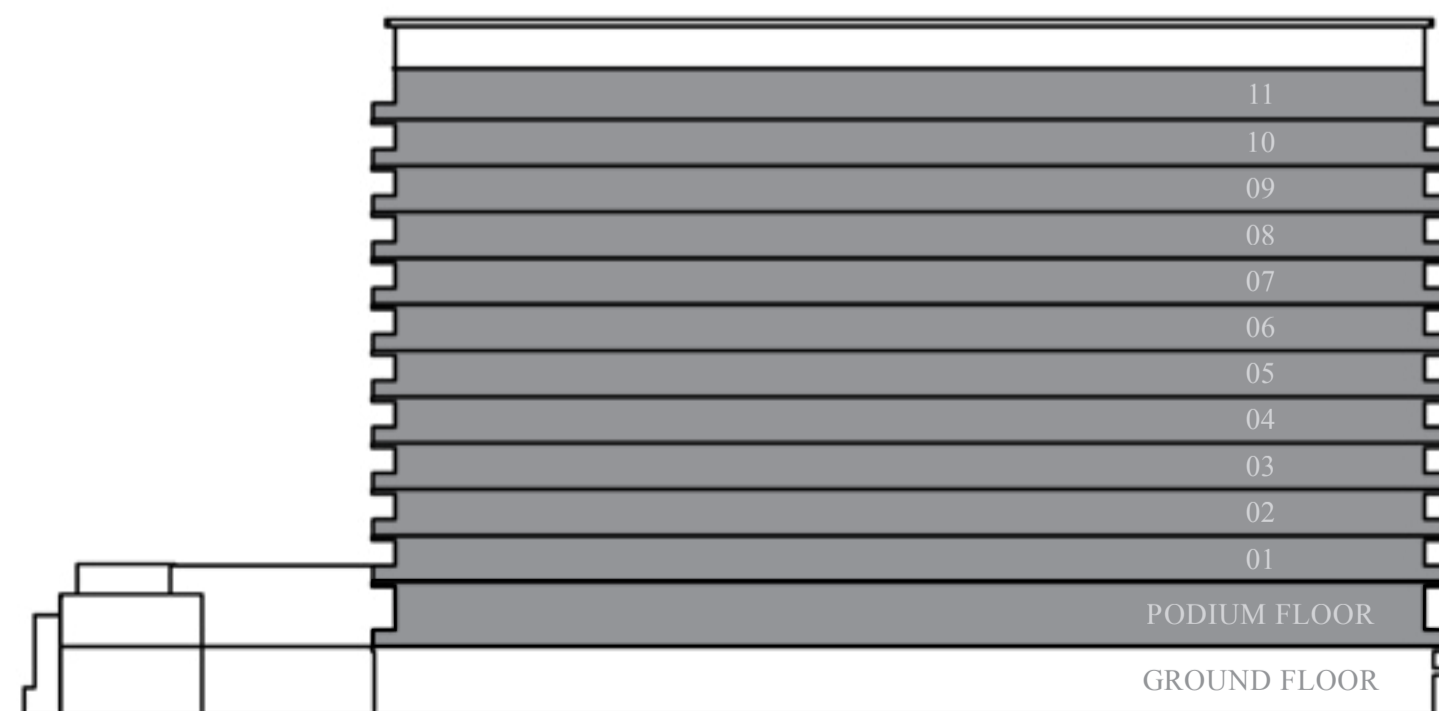

KEY PLANS

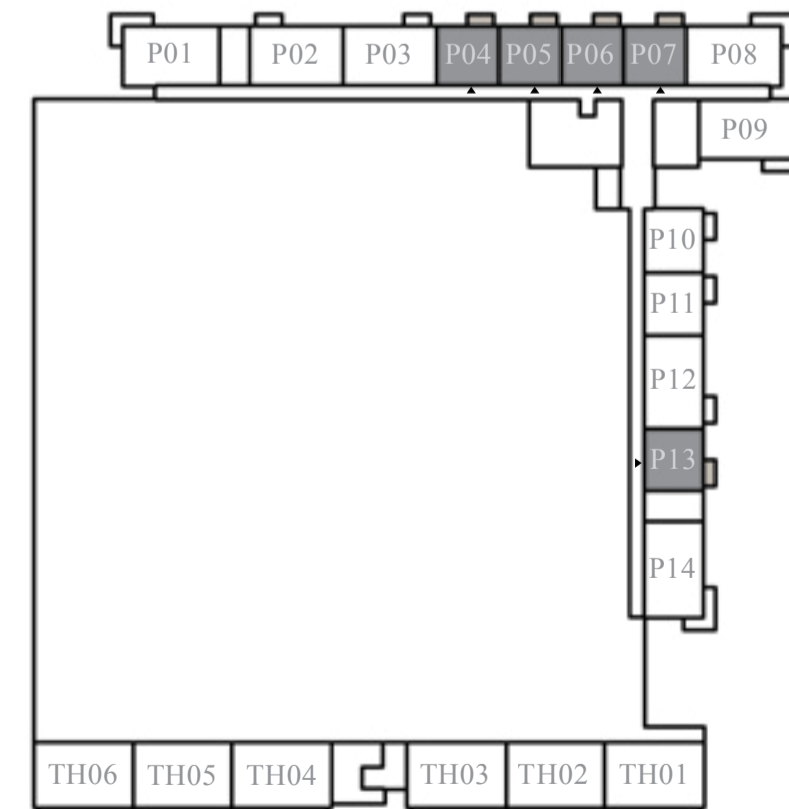

PODIUM FLOOR

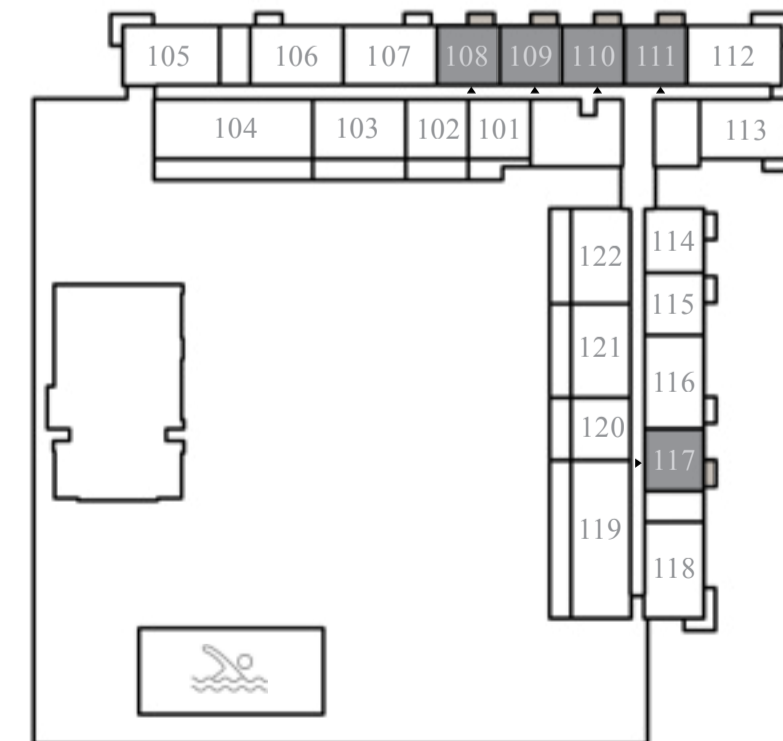

FIRST FLOOR

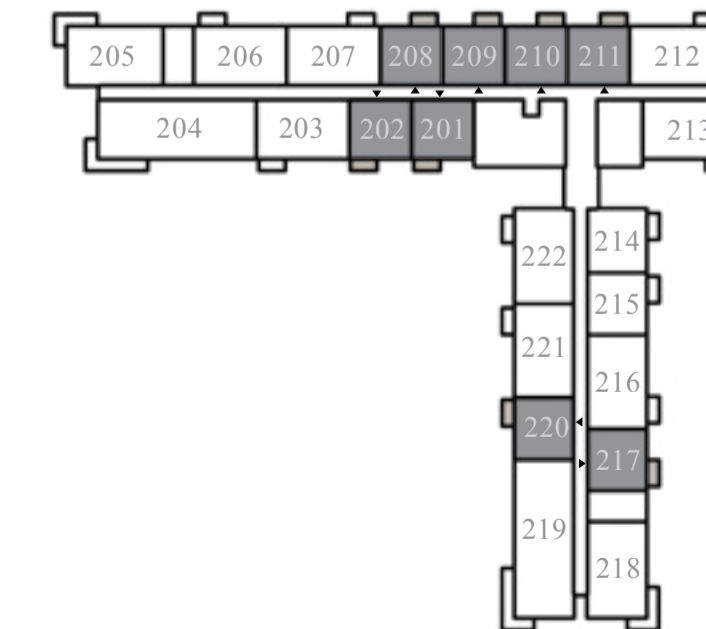

TYPICAL FLOOR (2-11)

FLOOR PLAN 1. All dimensions are in imperial and metric, and measured from finish to finish excluding construction tolerances. 2. All materials, dimensions, and drawings are approximate only. 3. Information is subject to change without notice, at developer's absolute discretion. 4. Actual area may vary from the stated area. 5. Drawings not to scale. 6. All images used are for illustrative purposes only and do not represent the actual size, features, specifications, fittings, and furnishings. 7. The developer reserves the right to make revisions / alterations, at its absolute discretion, without any liability whatsoever.

# golf vale

EMAAR SOUTH

## 1 BEDROOM-TYPE 1A

UNIT: P10, 114, 214, 314, 414, 514, 614, 714, 814, 914, 1014, 1114

SUITE AREA	58.16	SQM	626.03	SQFT
BALCONY AREA	04.98	SQM	53.60	SQFT
TOTAL AREA	63.14	SQM	679.63	SQFT

UNIT: P11, 115, 215, 315, 415, 515, 615, 715, 815, 915, 1015, 1115

SUITE AREA	57.82	SQM	622.37	SQFT
BALCONY AREA	04.98	SQM	53.60	SQFT
TOTAL AREA	62.80	SQM	675.97	SQFT



KEY SECTION

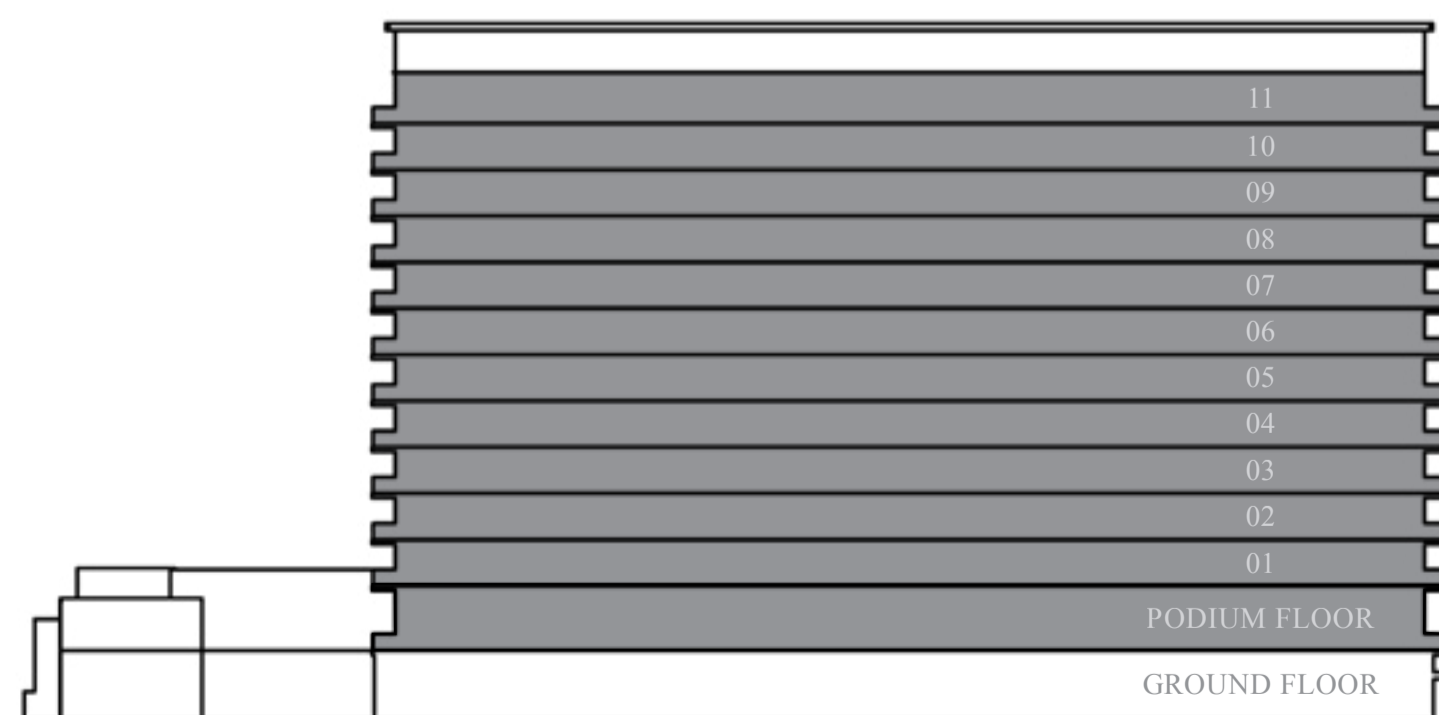

KEY PLANS

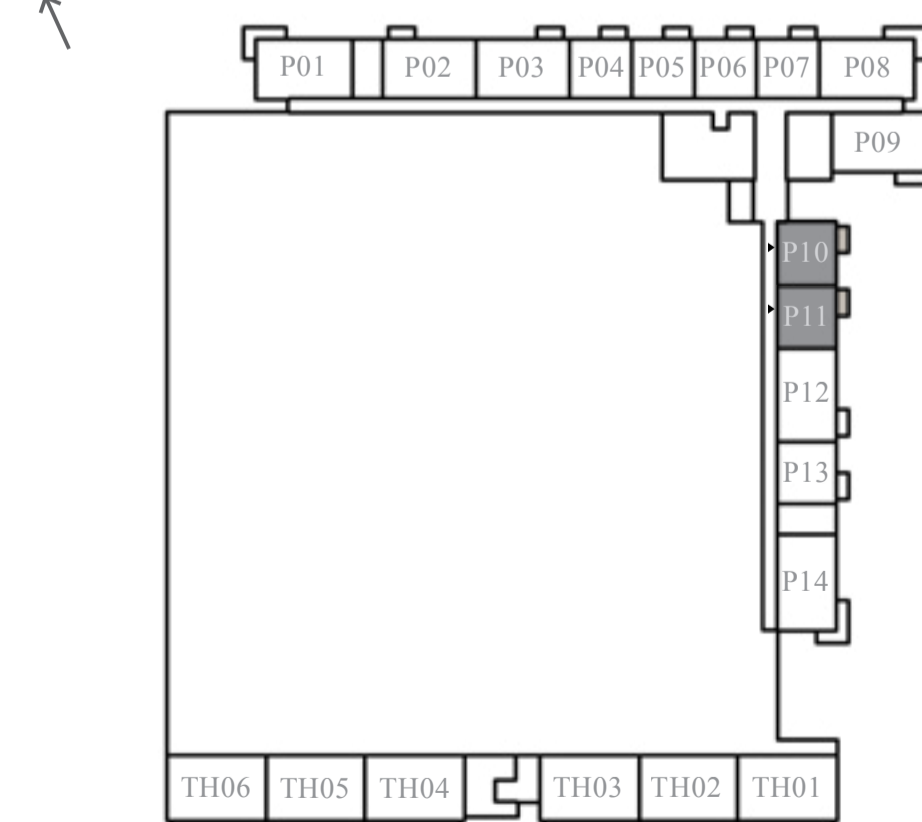

PODIUM FLOOR

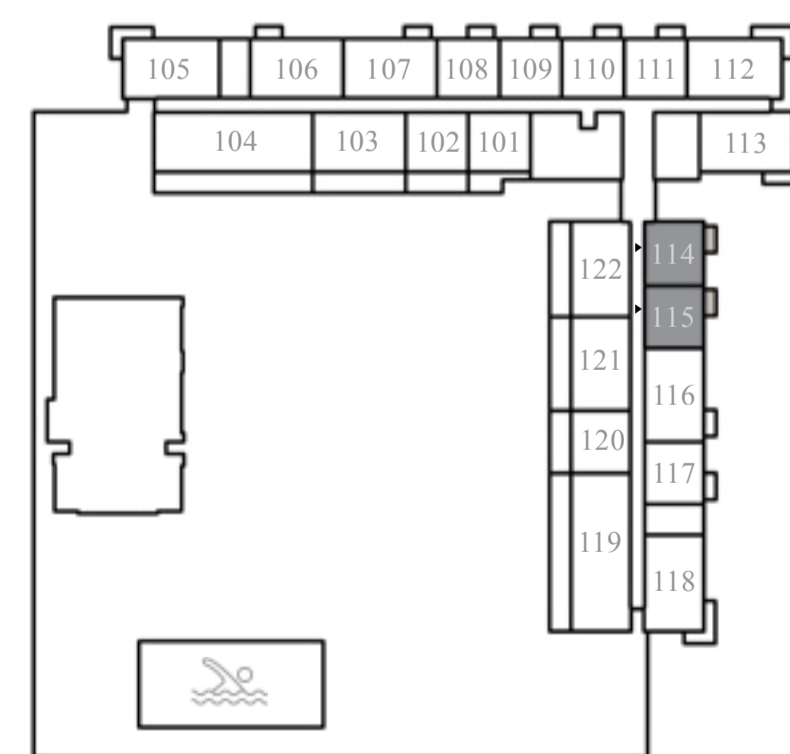

FIRST FLOOR

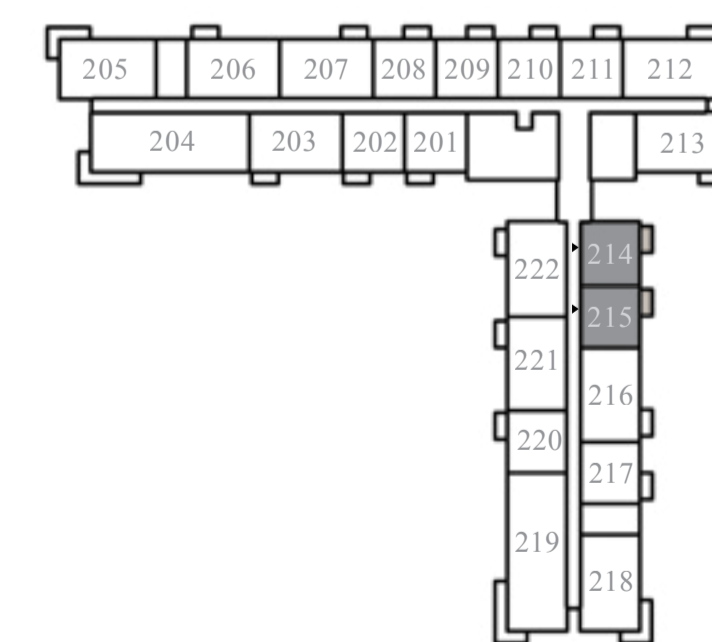

TYPICAL FLOOR (2-11)

FLOOR PLAN 1. All dimensions are in imperial and metric, and measured from finish to finish excluding construction tolerances. 2. All materials, dimensions, and drawings are approximate only. 3. Information is subject to change without notice, at developer's absolute discretion. 4. Actual area may vary from the stated area. 5. Drawings not to scale. 6. All images used are for illustrative purposes only and do not represent the actual size, features, specifications, fittings, and furnishings. 7. The developer reserves the right to make revisions / alterations, at its absolute discretion, without any liability whatsoever.

# golf vale

EMAAR SOUTH

## 1 BEDROOM-TYPE 2

UNIT: 102

SUITE AREA	57.84	SQM	622.58	SQFT
BALCONY AREA	22.86	SQM	246.10	SQFT
TOTAL AREA	80.70	SQM	868.65	SQFT

UNIT: 120

SUITE AREA	57.62	SQM	620.22	SQFT
BALCONY AREA	22.87	SQM	246.20	SQFT
TOTAL AREA	80.49	SQM	866.39	SQFT



KEY SECTION

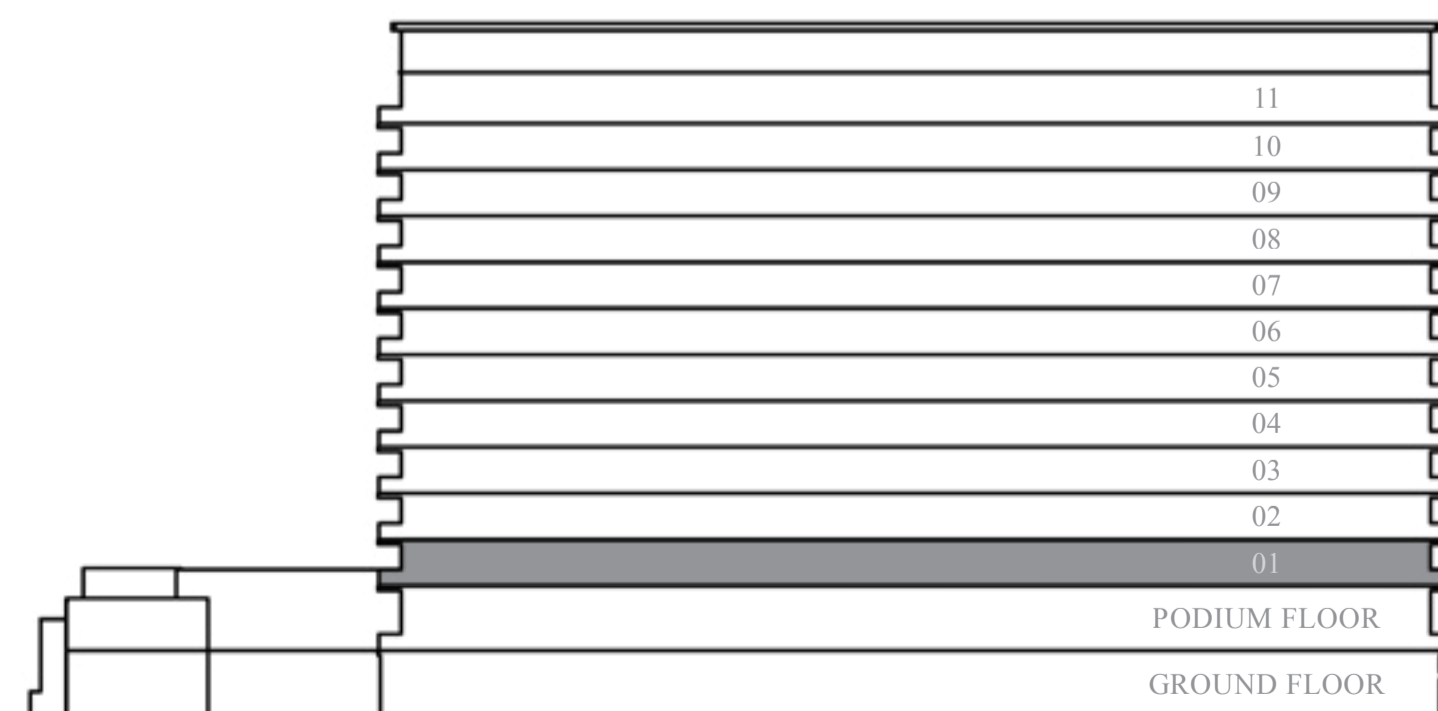

KEY PLANS



FIRST FLOOR

FLOOR PLAN 1. All dimensions are in imperial and metric, and measured from finish to finish excluding construction tolerances. 2. All materials, dimensions, and drawings are approximate only. 3. Information is subject to change without notice, at developer's absolute discretion. 4. Actual area may vary from the stated area. 5. Drawings not to scale. 6. All images used are for illustrative purposes only and do not represent the actual size, features, specifications, fittings, and furnishings. 7. The developer reserves the right to make revisions / alterations, at its absolute discretion, without any liability whatsoever.

# golf vale

EMAAR SOUTH

## 1 BEDROOM-TYPE 3

UNIT: 101

SUITE AREA	57.81	SQM	622.26	SQFT
BALCONY AREA	16.50	SQM	178.00	SQFT
TOTAL AREA	74.35	SQM	800.30	SQFT



KEY SECTION

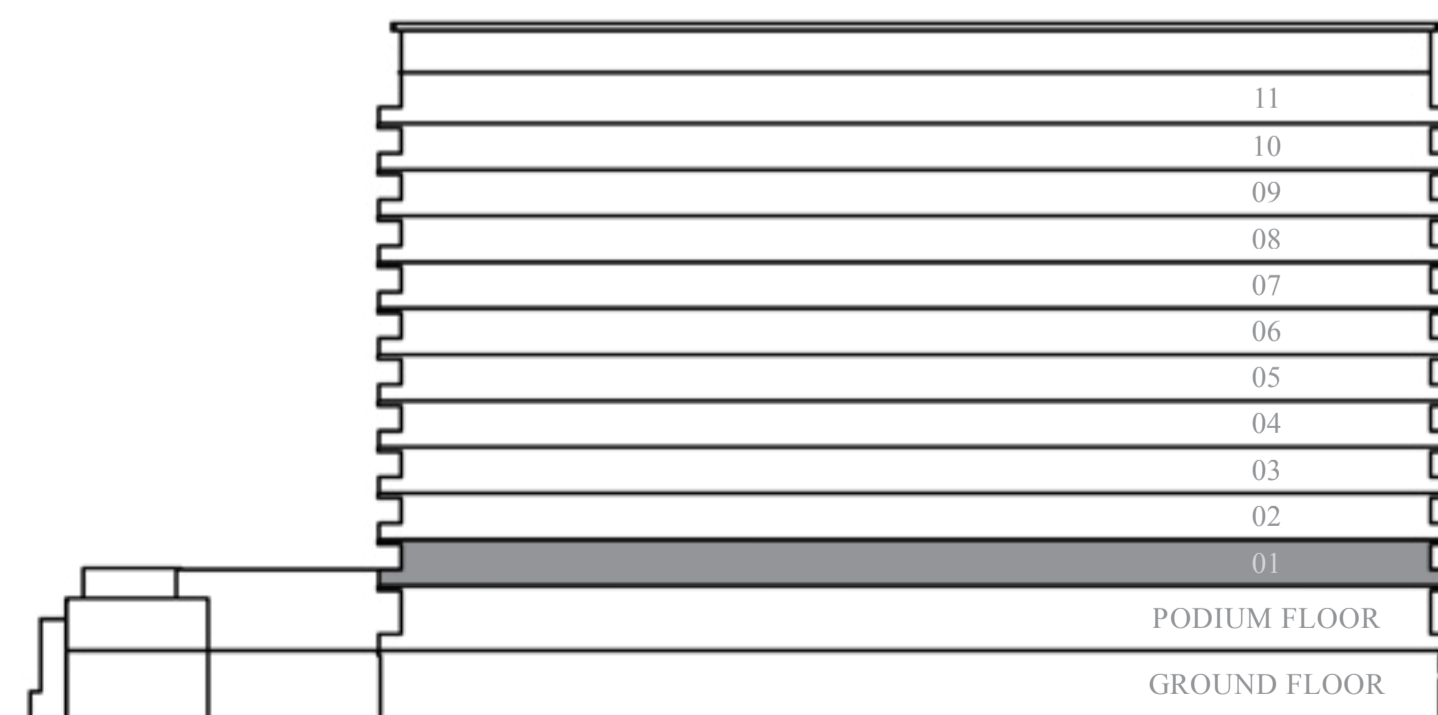

KEY PLANS

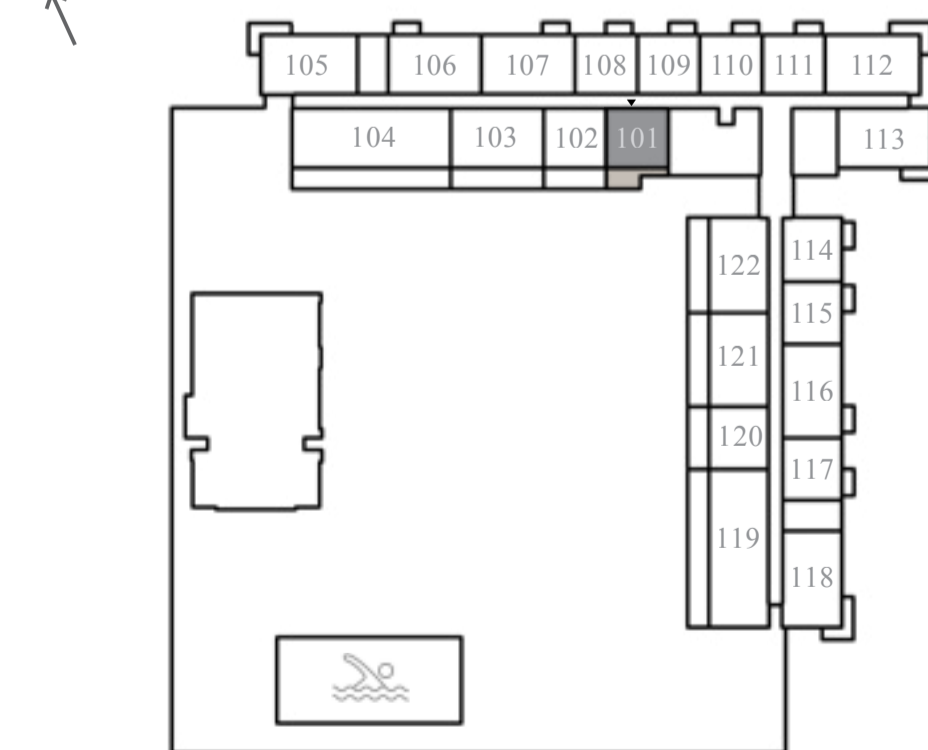

FIRST FLOOR

FLOOR PLAN 1. All dimensions are in imperial and metric, and measured from finish to finish excluding construction tolerances. 2. All materials, dimensions, and drawings are approximate only. 3. Information is subject to change without notice, at developer's absolute discretion. 4. Actual area may vary from the stated area. 5. Drawings not to scale. 6. All images used are for illustrative purposes only and do not represent the actual size, features, specifications, fittings, and furnishings. 7. The developer reserves the right to make revisions / alterations, at its absolute discretion, without any liability whatsoever.

# golf vale

EMAAR SOUTH

## 2 BEDROOM-TYPE 1

UNIT: 203, 303, 403, 503, 603, 703, 803, 903, 1003, 1103

SUITE AREA	86.74	SQM	933.66	SQFT
BALCONY AREA	04.98	SQM	53.60	SQFT
TOTAL AREA	91.72	SQM	987.27	SQFT

UNIT: P03, P12, 107, 116, 207, 307, 407, 507, 607, 707, 807, 907, 1007, 1107, 216, 316, 416, 516, 616, 716, 816, 916, 1016, 1116, 221, 321, 421, 521, 621, 721, 821, 921, 1021, 1121

SUITE AREA	86.98	SQM	936.14	SQFT
BALCONY AREA	04.98	SQM	53.60	SQFT
TOTAL AREA	91.95	SQM	989.74	SQFT

UNIT: 222, 322, 422, 522, 622, 722, 822, 922, 1022, 1122

SUITE AREA	87.31	SQM	939.80	SQFT
BALCONY AREA	04.98	SQM	53.60	SQFT
TOTAL AREA	92.29	SQM	993.40	SQFT

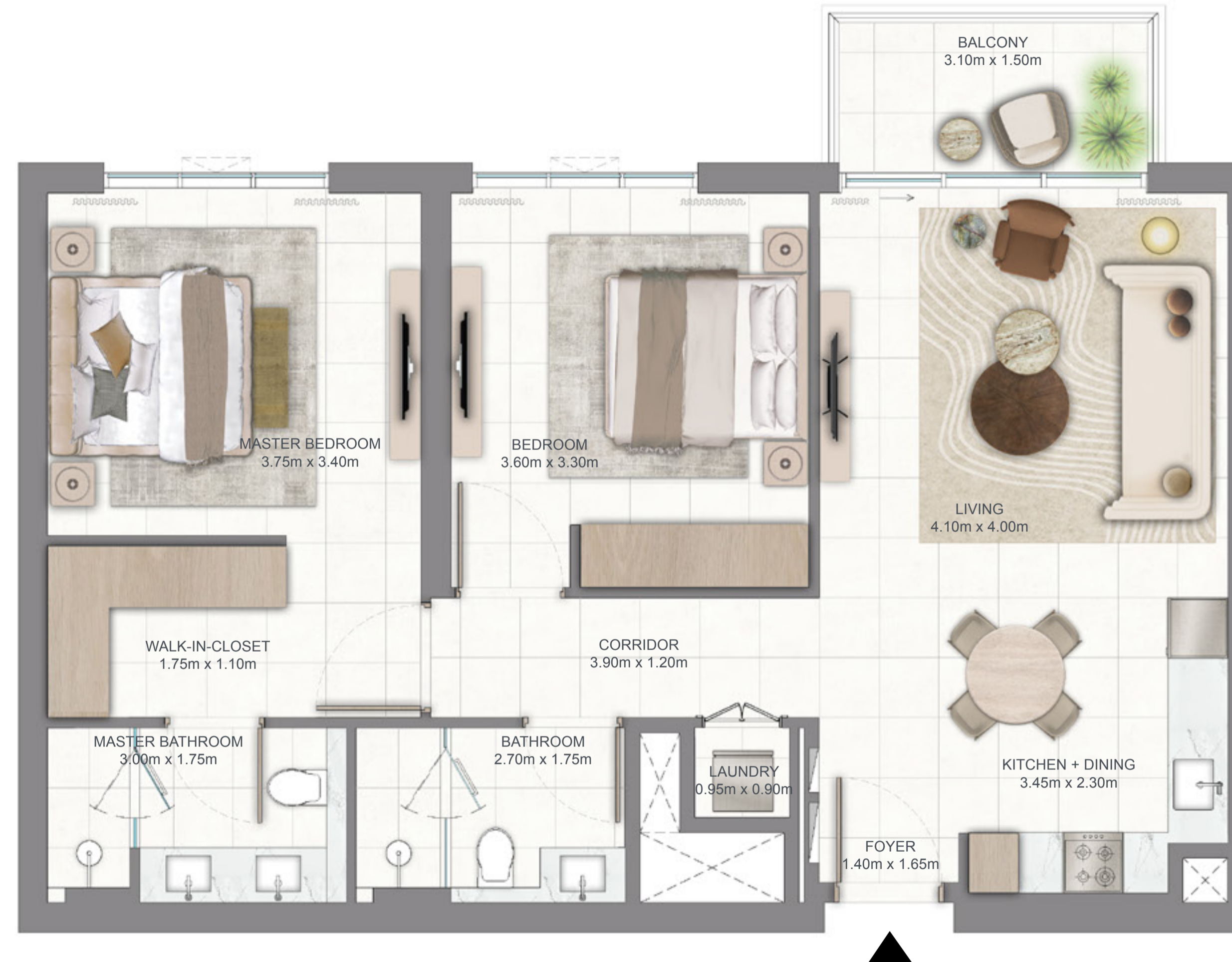

KEY SECTION

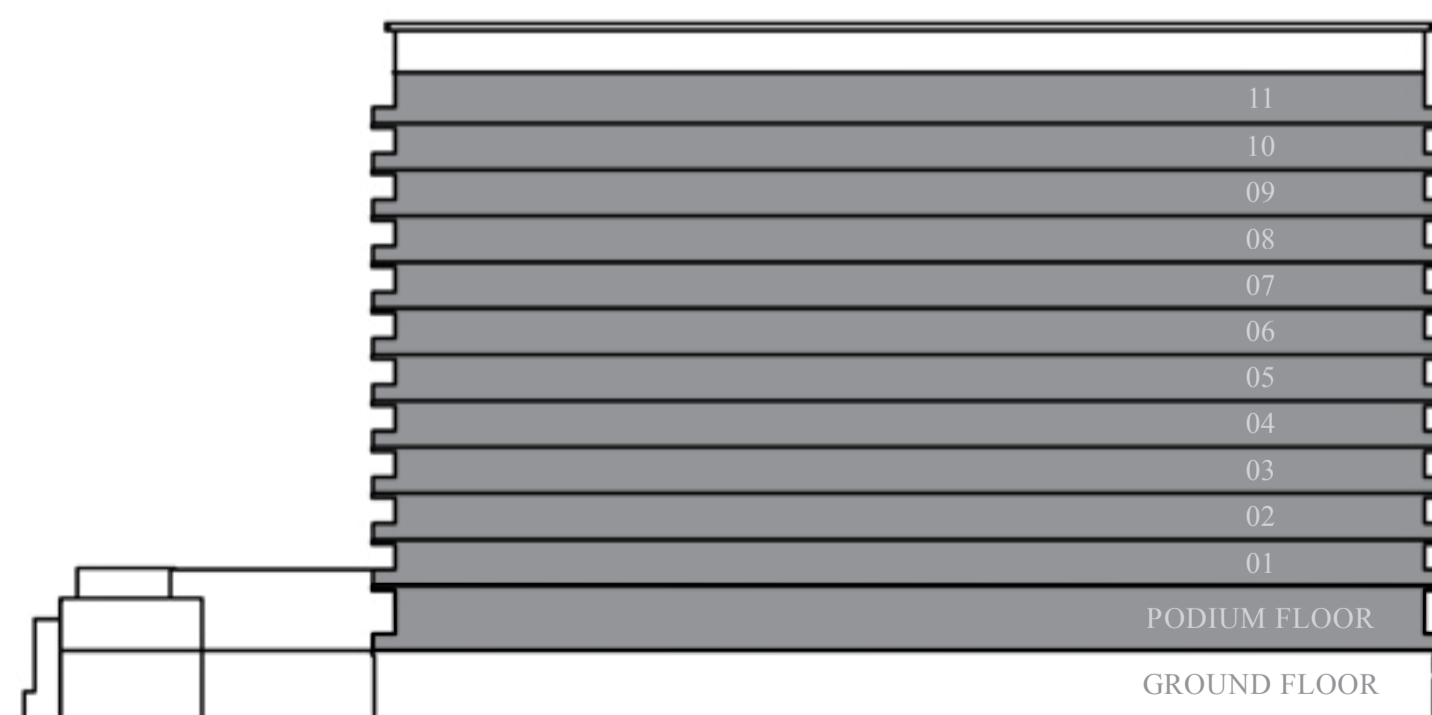

KEY PLANS

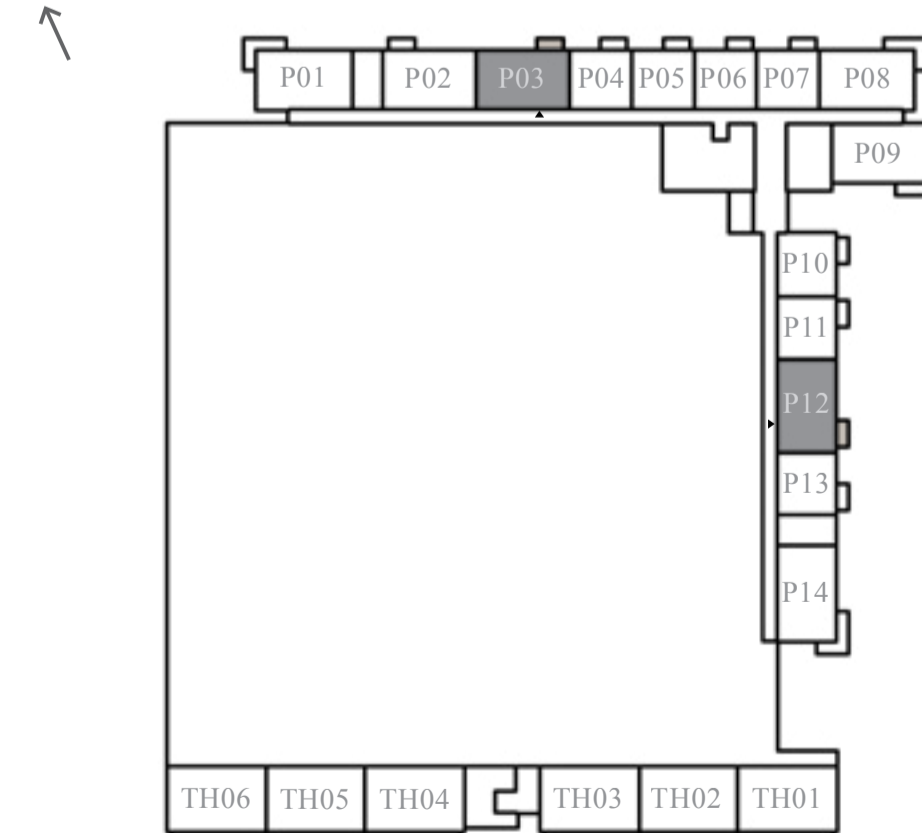

PODIUM FLOOR

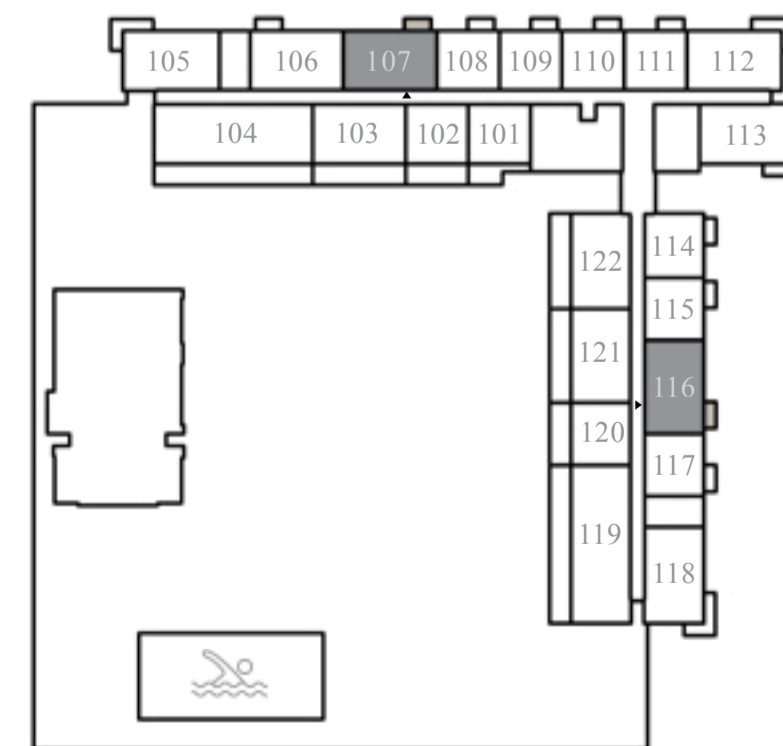

FIRST FLOOR

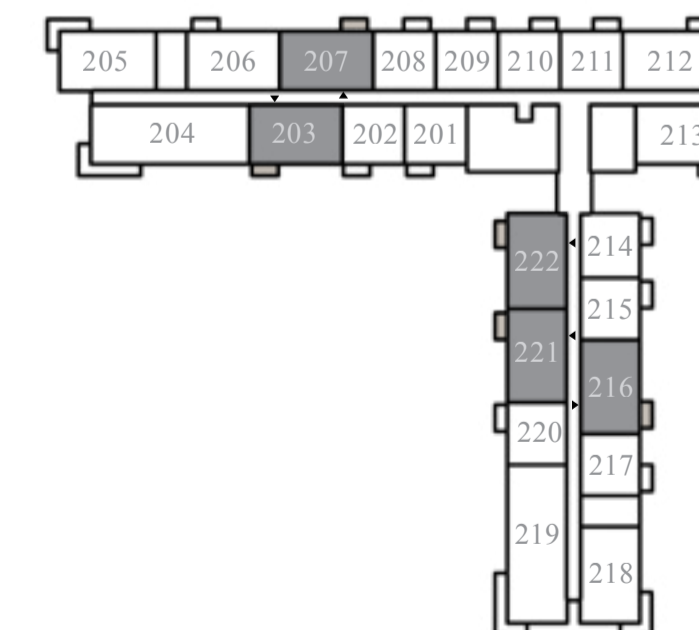

TYPICAL FLOOR (2-11)

FLOOR PLAN 1. All dimensions are in imperial and metric, and measured from finish to finish excluding construction tolerances. 2. All materials, dimensions, and drawings are approximate only. 3. Information is subject to change without notice, at developer's absolute discretion. 4. Actual area may vary from the stated area. 5. Drawings not to scale. 6. All images used are for illustrative purposes only and do not represent the actual size, features, specifications, fittings, and furnishings. 7. The developer reserves the right to make revisions / alterations, at its absolute discretion, without any liability whatsoever.

# golf vale

EMAAR SOUTH

## 2 BEDROOM-TYPE 1A

UNIT: P02, 106, 206, 306, 406, 506, 606, 706, 806, 906, 1006, 1106

SUITE AREA	86.64	SQM	932.59	SQFT
BALCONY AREA	4.98	SQM	53.60	SQFT
TOTAL AREA	91.62	SQM	986.19	SQFT



KEY SECTION

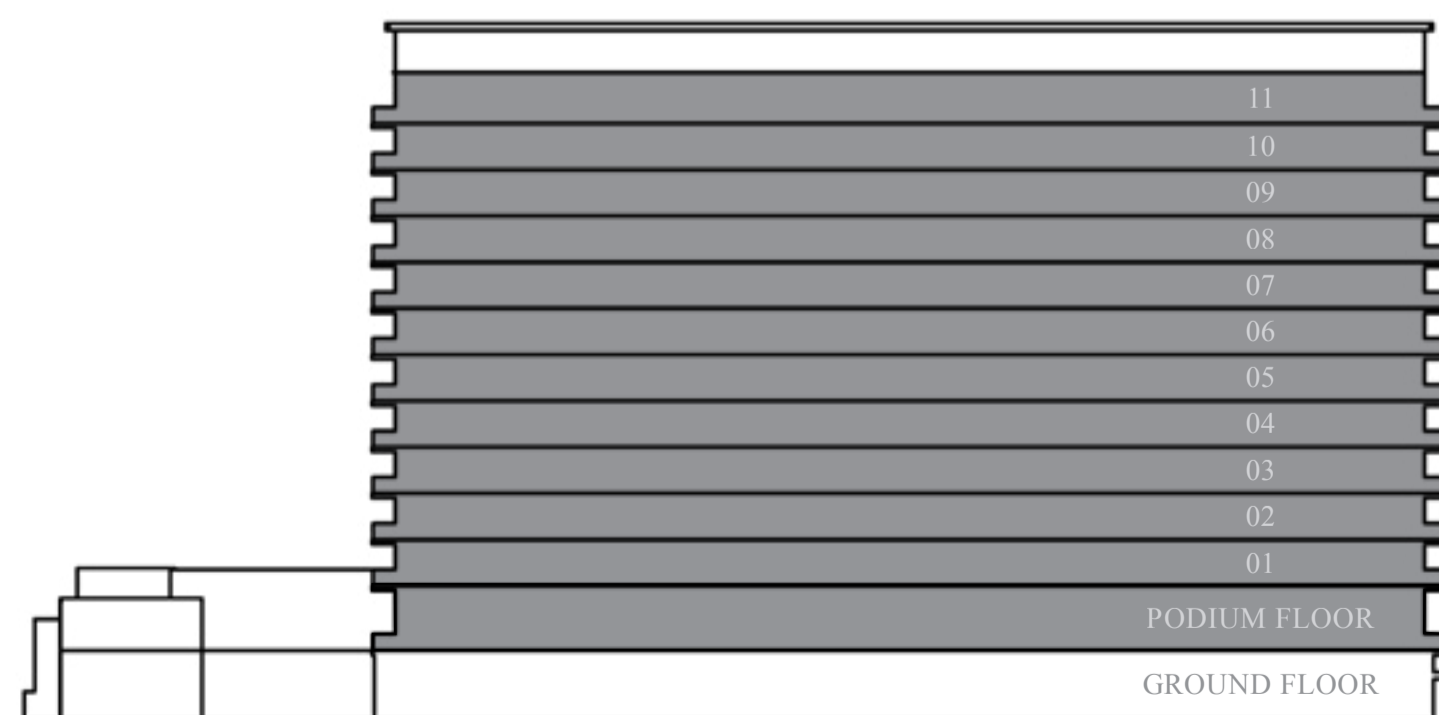

KEY PLANS

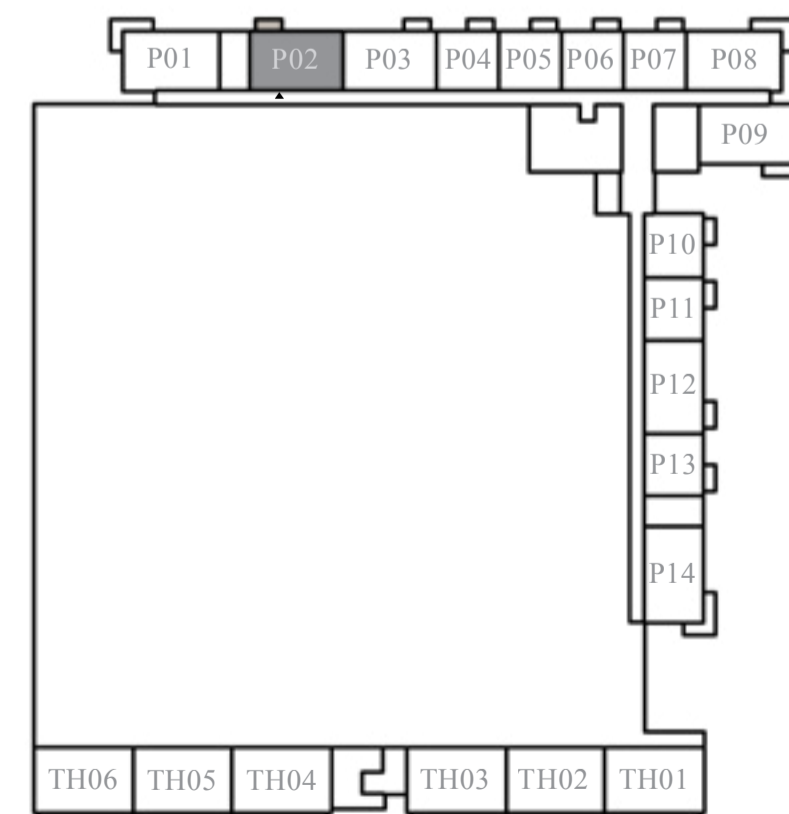

PODIUM FLOOR

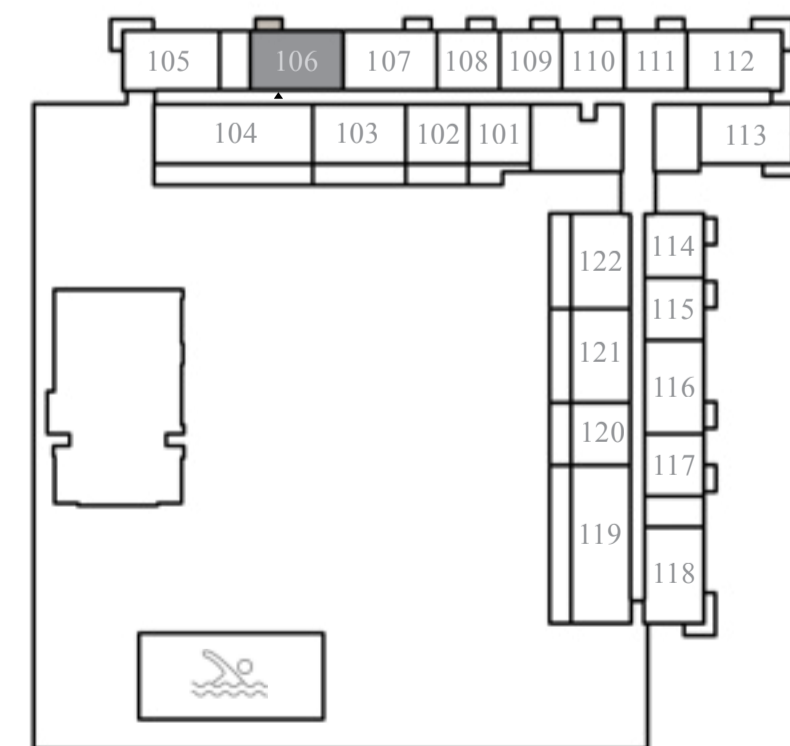

FIRST FLOOR

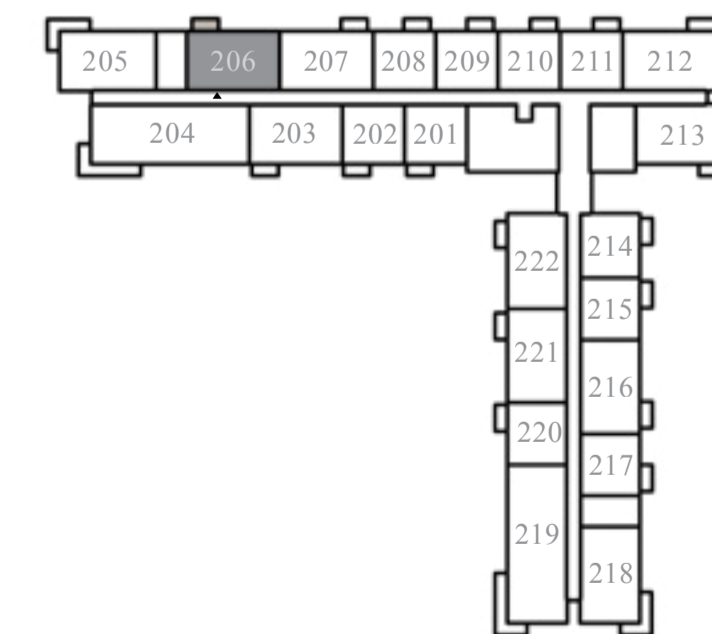

TYPICAL FLOOR (2-11)

FLOOR PLAN 1. All dimensions are in imperial and metric, and measured from finish to finish excluding construction tolerances. 2. All materials, dimensions, and drawings are approximate only. 3. Information is subject to change without notice, at developer's absolute discretion. 4. Actual area may vary from the stated area. 5. Drawings not to scale. 6. All images used are for illustrative purposes only and do not represent the actual size, features, specifications, fittings, and furnishings. 7. The developer reserves the right to make revisions / alterations, at its absolute discretion, without any liability whatsoever.

# golf vale

EMAAR SOUTH

## 2 BEDROOM-TYPE 2

UNIT: P08, 112, 212, 312, 412, 512, 612, 712, 812, 912, 1012, 1112, 218, 418, 618, 818, 1018

SUITE AREA	86.30	SQM	928.93	SQFT
BALCONY AREA	12.27	SQM	132.10	SQFT
TOTAL AREA	98.57	SQM	1061.00	SQFT

UNIT: 318, 518, 718, 918, 1118

SUITE AREA	87.00	SQM	936.46	SQFT
BALCONY AREA	11.72	SQM	126.20	SQFT
TOTAL AREA	98.72	SQM	1062.60	SQFT

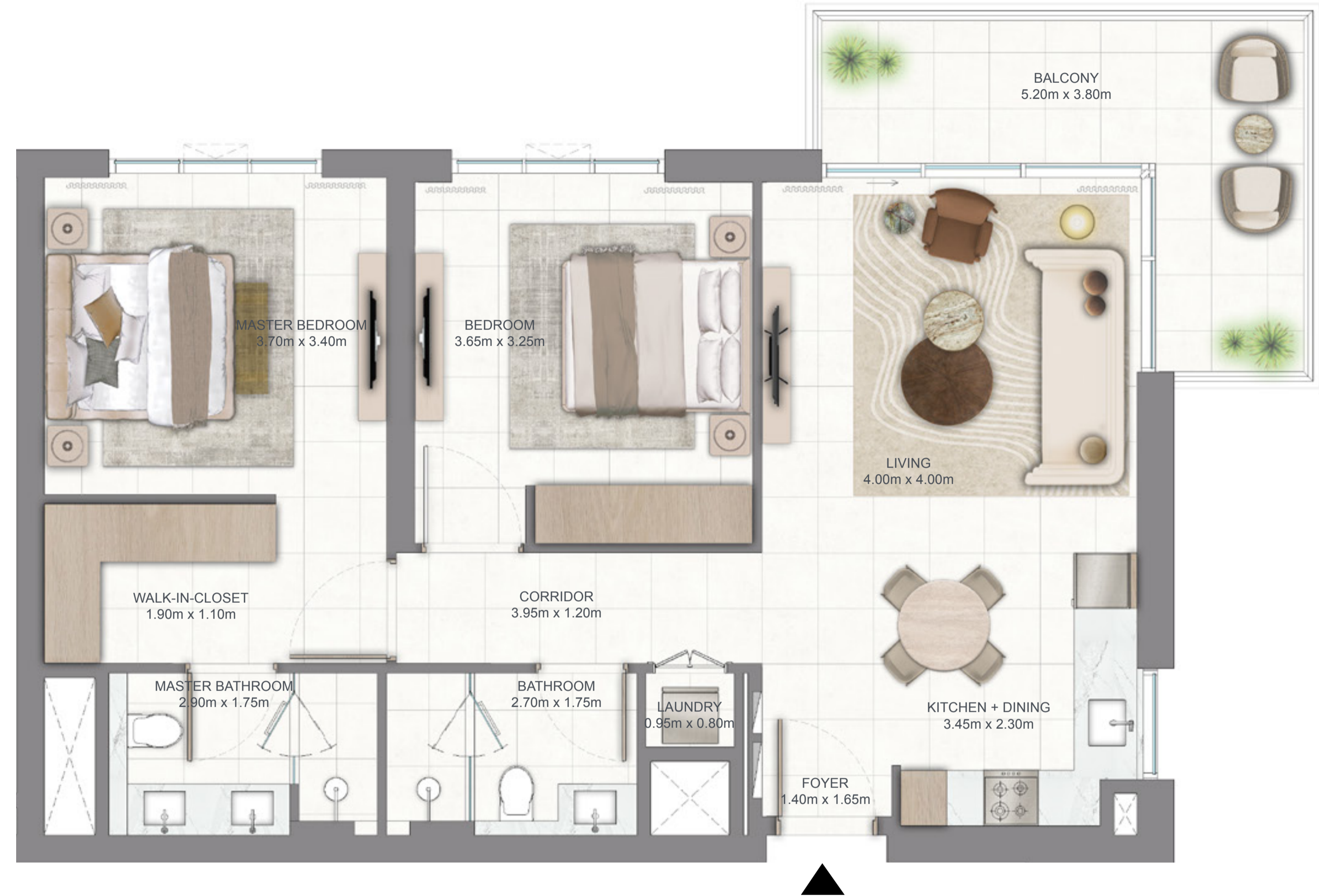

KEY SECTION

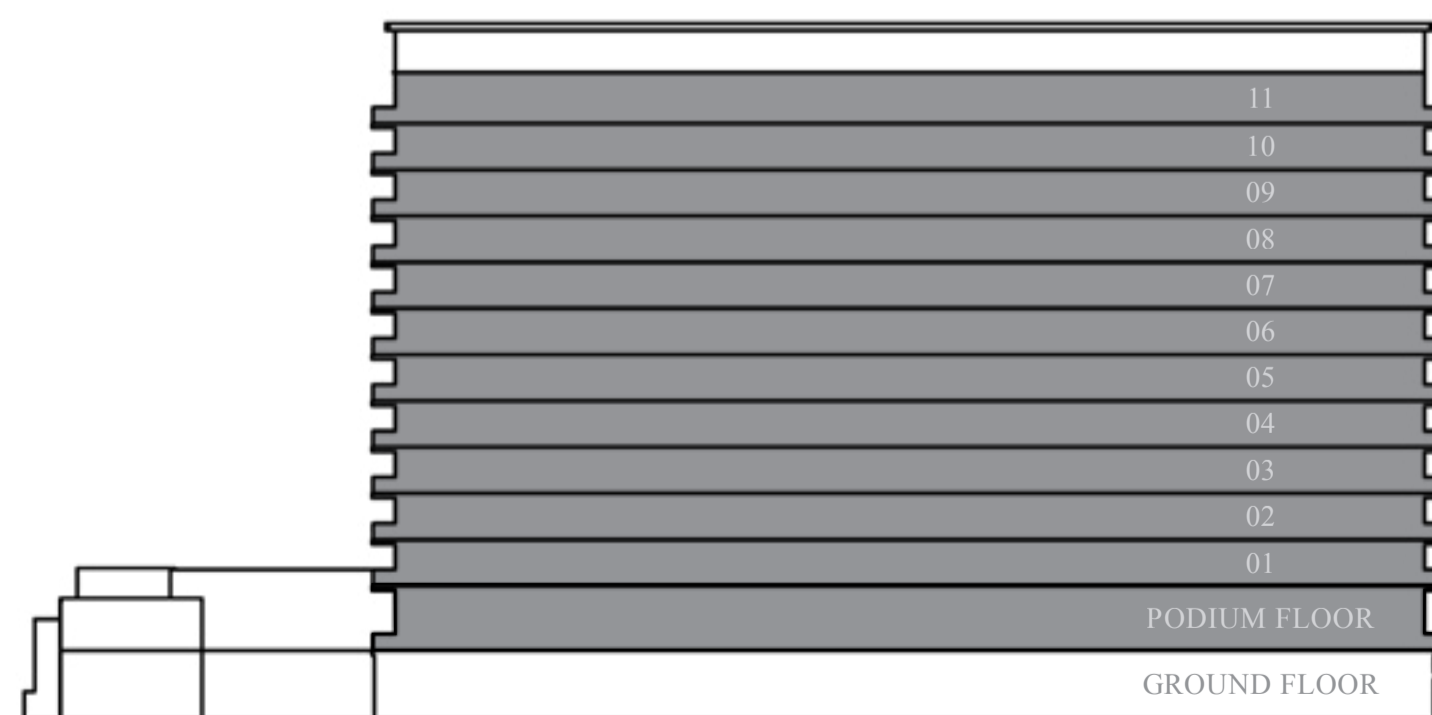

KEY PLANS

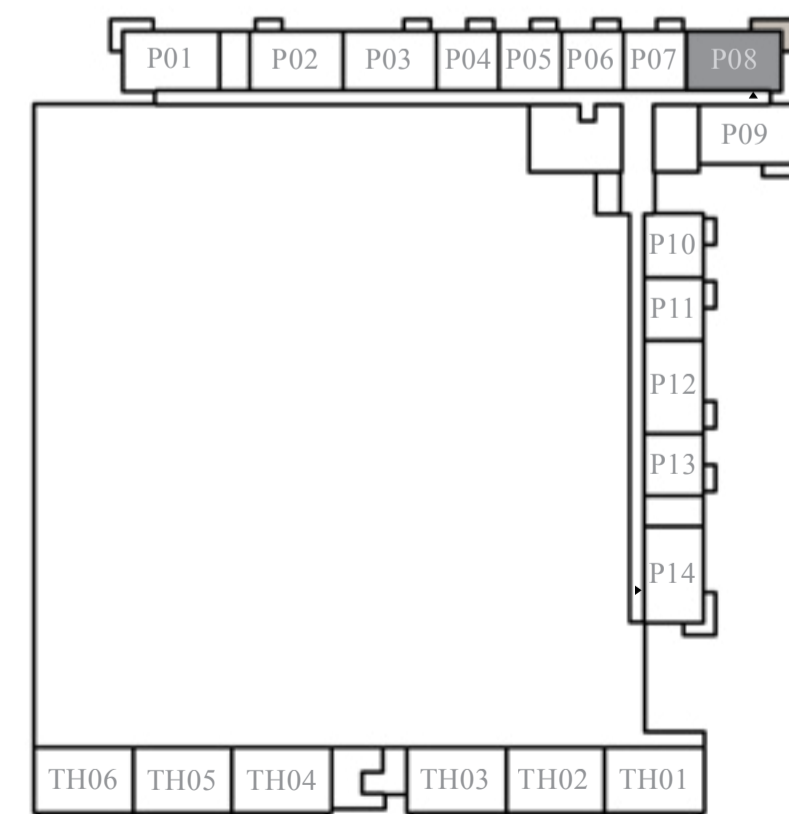

PODIUM FLOOR

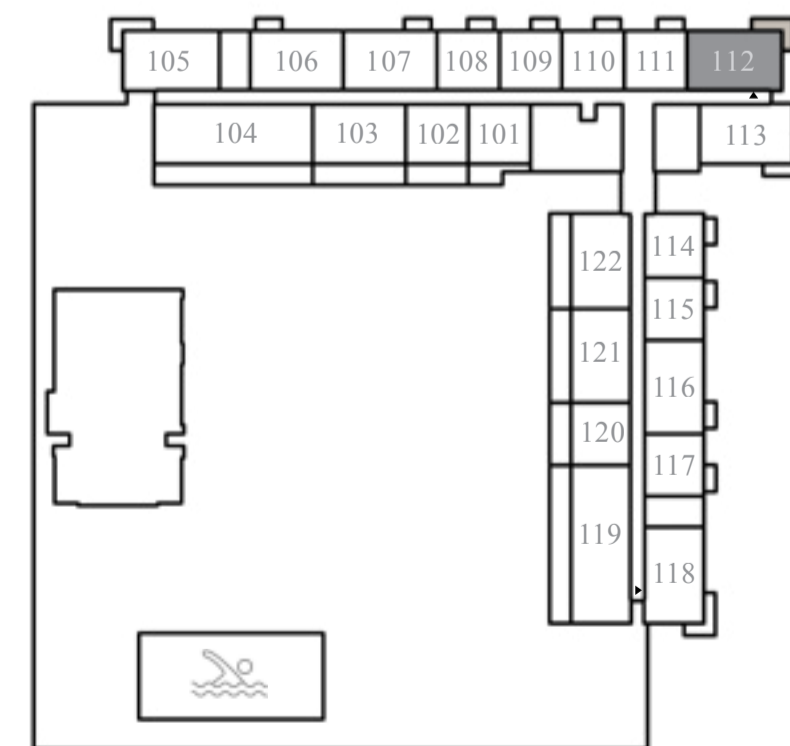

FIRST FLOOR

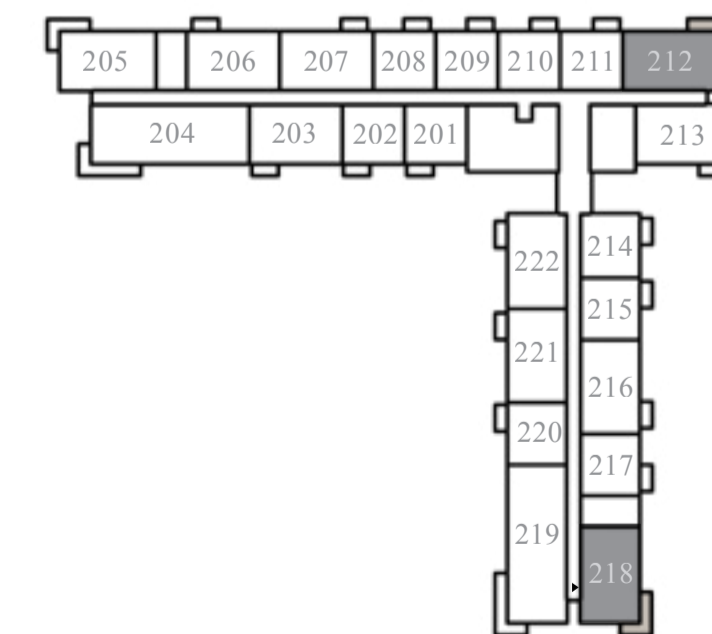

TYPICAL FLOOR (2-11)

FLOOR PLAN 1. All dimensions are in imperial and metric, and measured from finish to finish excluding construction tolerances. 2. All materials, dimensions, and drawings are approximate only. 3. Information is subject to change without notice, at developer's absolute discretion. 4. Actual area may vary from the stated area. 5. Drawings not to scale. 6. All images used are for illustrative purposes only and do not represent the actual size, features, specifications, fittings, and furnishings. 7. The developer reserves the right to make revisions / alterations, at its absolute discretion, without any liability whatsoever.

# golf vale

EMAAR SOUTH

## 2 BEDROOM-TYPE 2

UNIT: P14

SUITE AREA	87.08	SQM	937.32	SQFT
BALCONY AREA	12.24	SQM	131.80	SQFT
TOTAL AREA	99.32	SQM	1069.10	SQFT

UNIT: 118

SUITE AREA	87.17	SQM	938.29	SQFT
BALCONY AREA	11.72	SQM	126.20	SQFT
TOTAL AREA	98.89	SQM	1064.40	SQFT

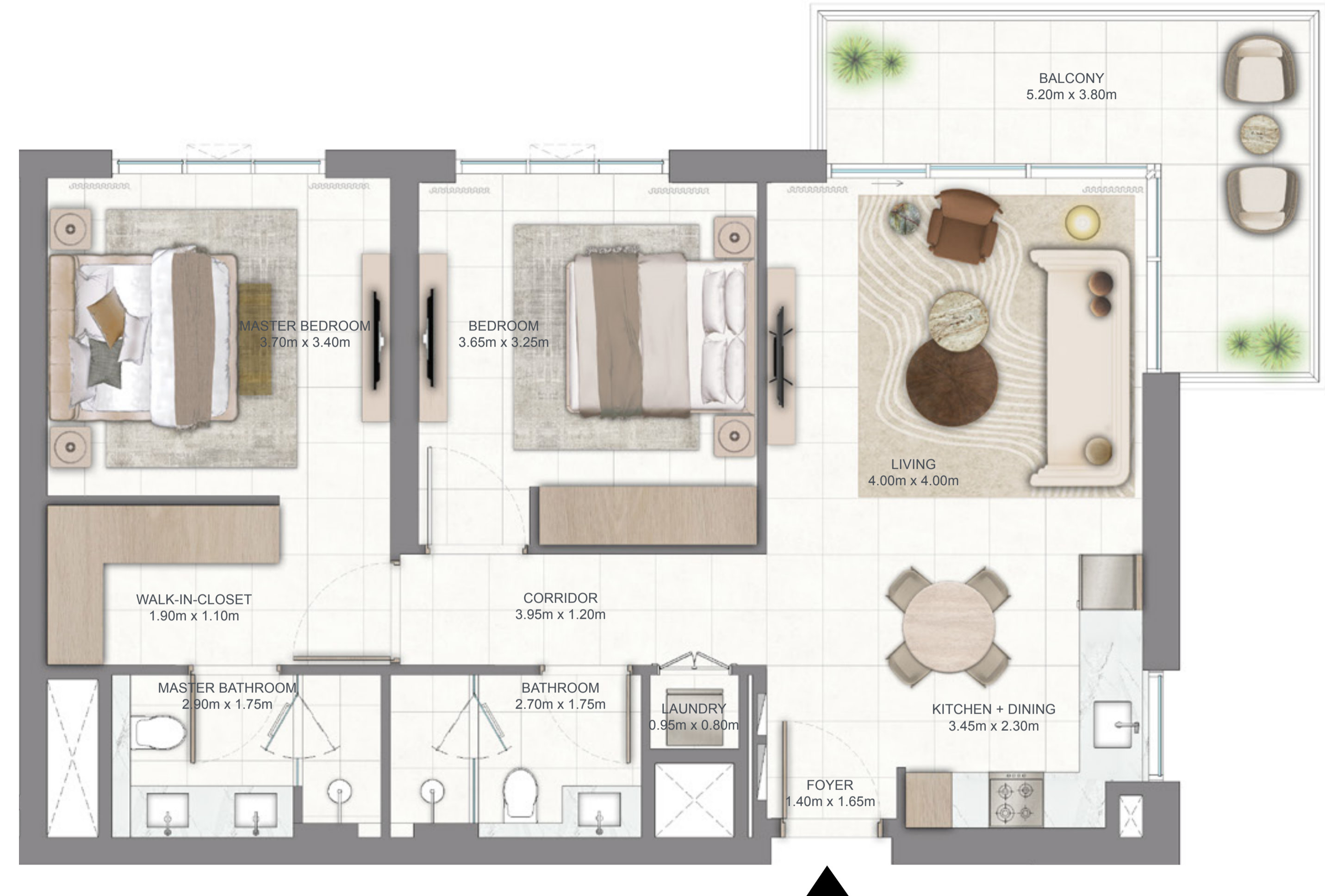

KEY SECTION

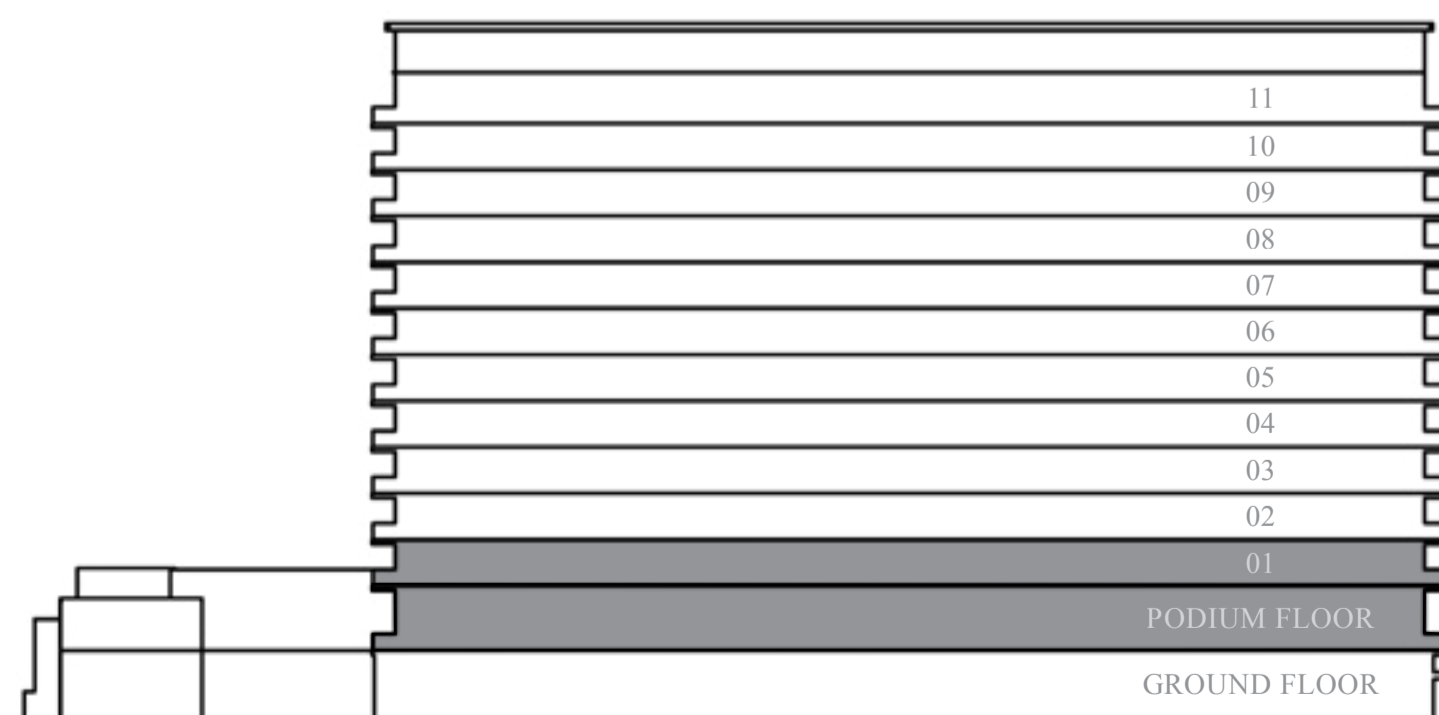

KEY PLANS

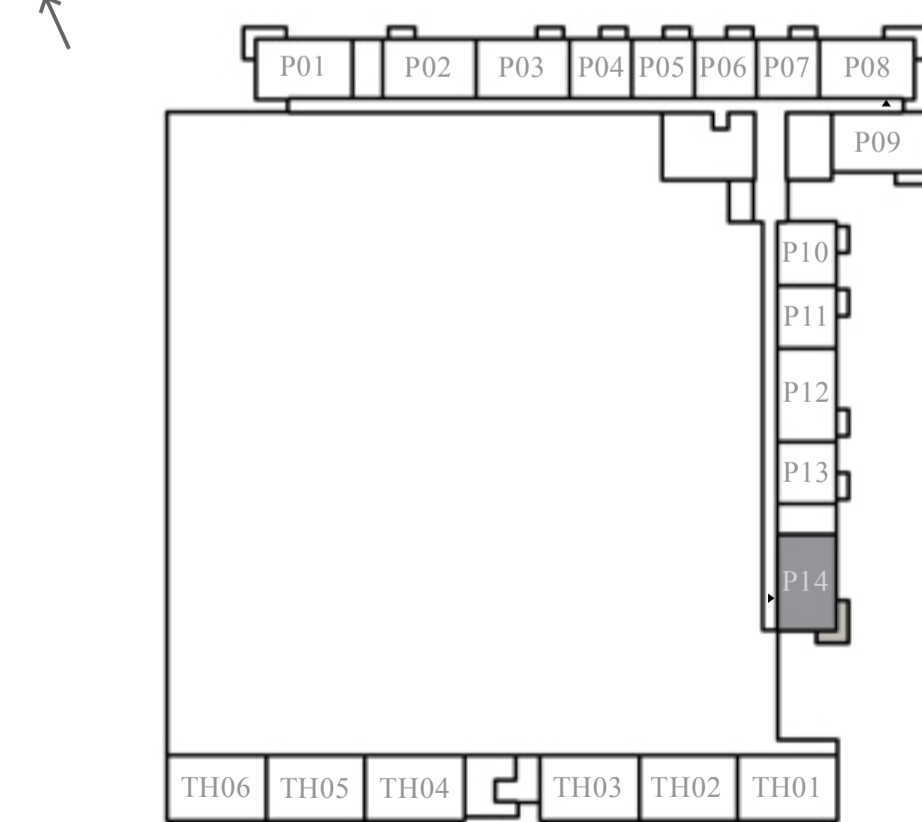

PODIUM FLOOR

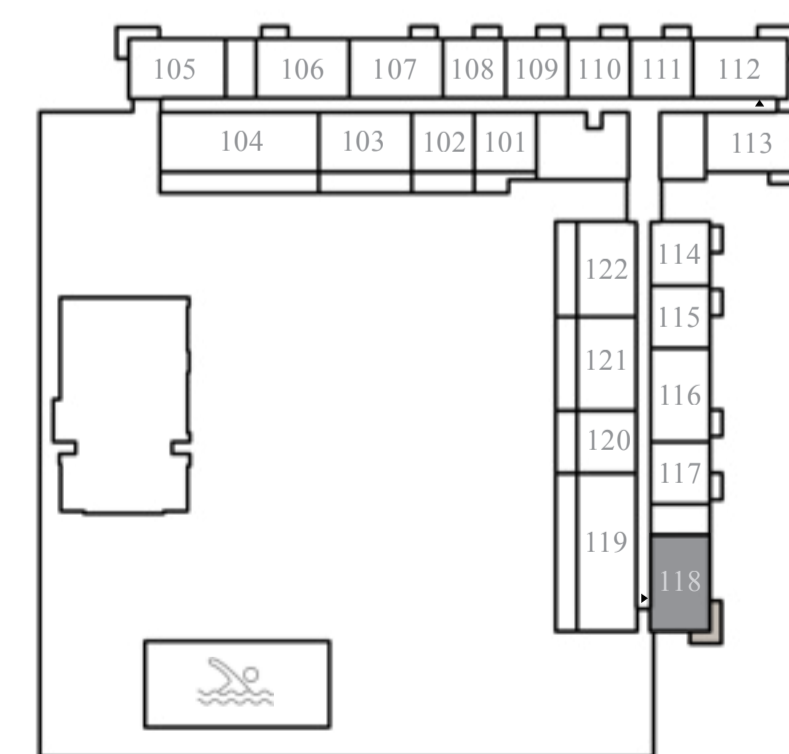

FIRST FLOOR

FLOOR PLAN 1. All dimensions are in imperial and metric, and measured from finish to finish excluding construction tolerances. 2. All materials, dimensions, and drawings are approximate only. 3. Information is subject to change without notice, at developer's absolute discretion. 4. Actual area may vary from the stated area. 5. Drawings not to scale. 6. All images used are for illustrative purposes only and do not represent the actual size, features, specifications, fittings, and furnishings. 7. The developer reserves the right to make revisions / alterations, at its absolute discretion, without any liability whatsoever.

# golf vale

EMAAR SOUTH

## 2 BEDROOM-TYPE 2A

UNIT: P09, 113, 213, 313, 413, 513, 613, 713, 813, 913, 1013, 1113

SUITE AREA	87.16	SQM	938.18	SQFT
BALCONY AREA	12.20	SQM	131.80	SQFT
TOTAL AREA	99.40	SQM	1069.90	SQFT



KEY SECTION

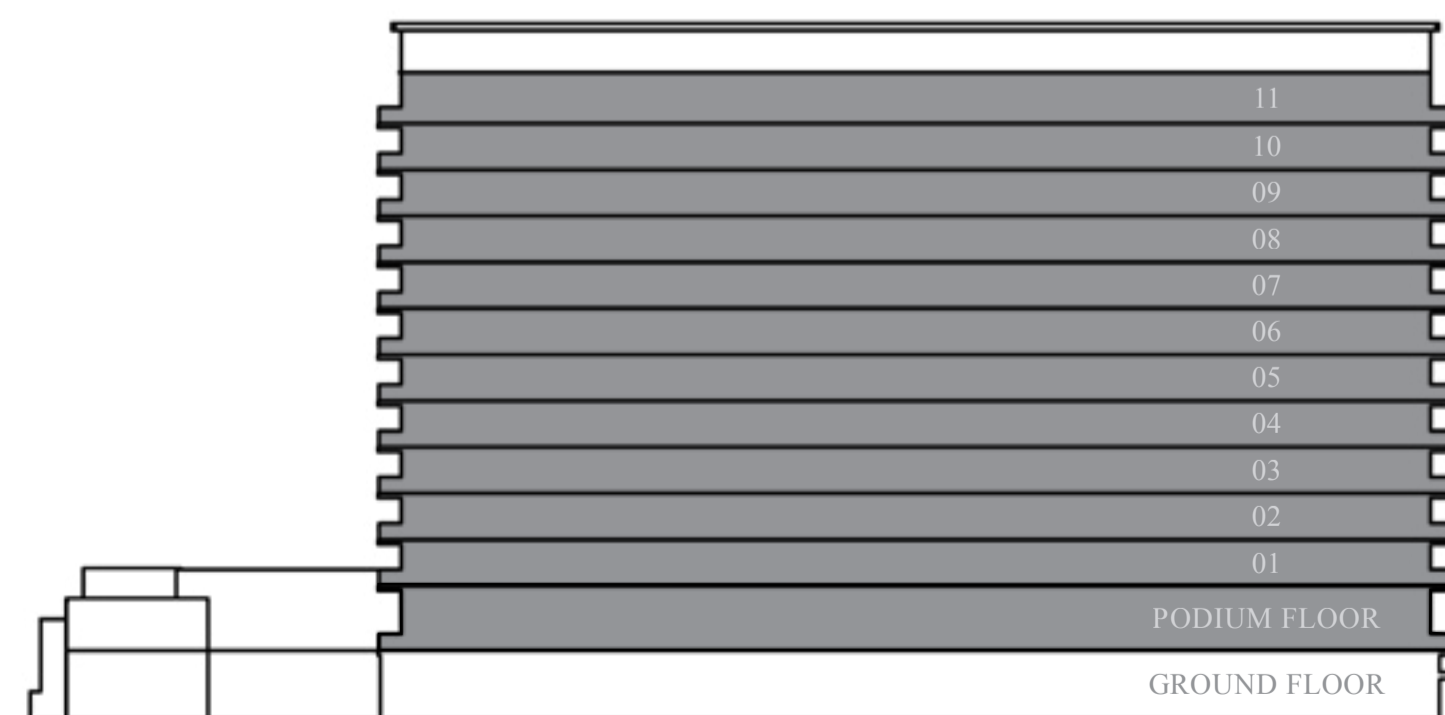

KEY PLANS

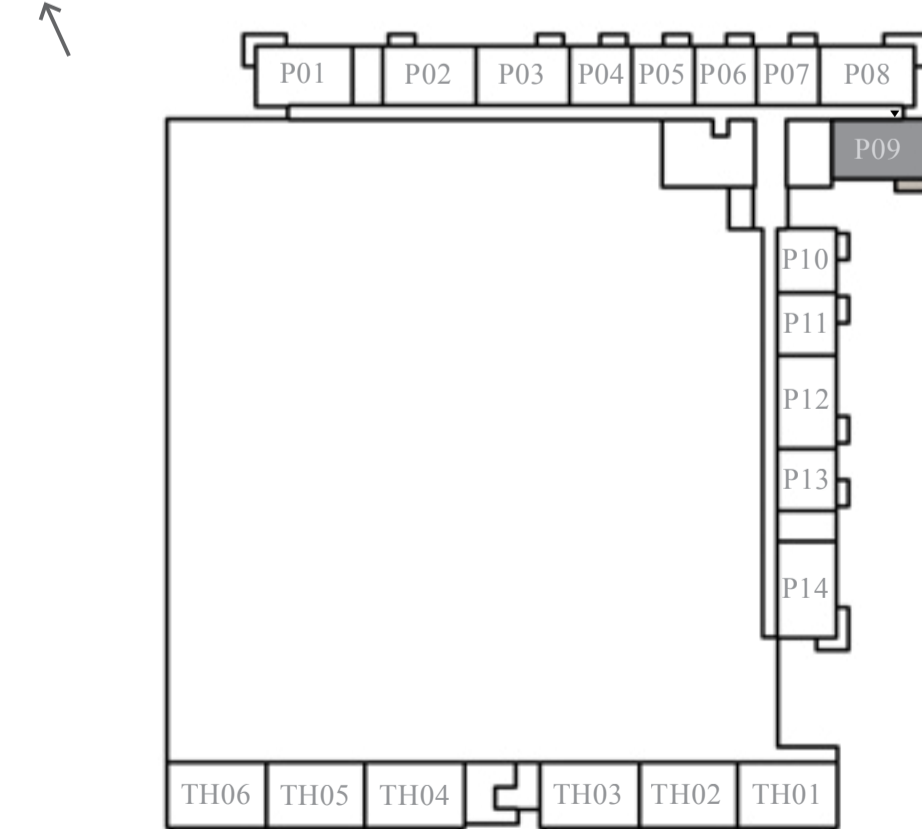

PODIUM FLOOR



FIRST FLOOR

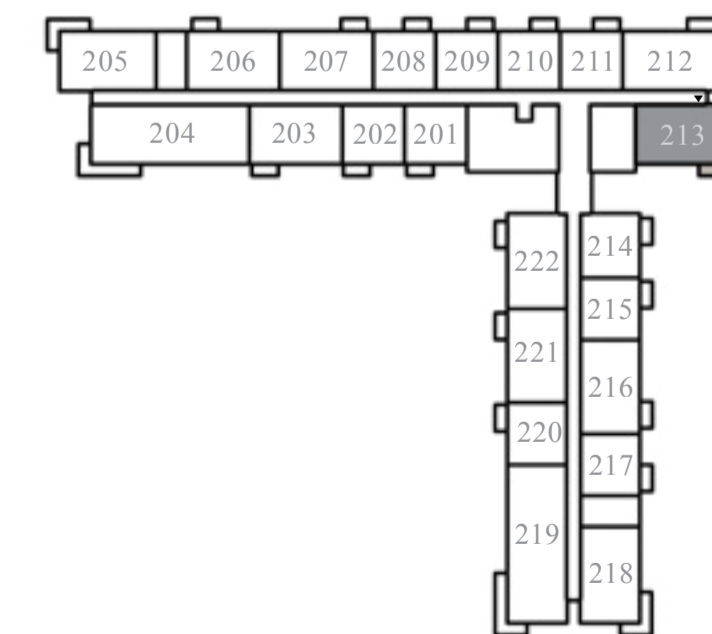

TYPICAL FLOOR (2-11)

FLOOR PLAN 1. All dimensions are in imperial and metric, and measured from finish to finish excluding construction tolerances. 2. All materials, dimensions, and drawings are approximate only. 3. Information is subject to change without notice, at developer's absolute discretion. 4. Actual area may vary from the stated area. 5. Drawings not to scale. 6. All images used are for illustrative purposes only and do not represent the actual size, features, specifications, fittings, and furnishings. 7. The developer reserves the right to make revisions / alterations, at its absolute discretion, without any liability whatsoever.

# golf vale

EMAAR SOUTH

## 2 BEDROOM-TYPE 3

UNIT: P01

SUITE AREA	88.42	SQM	951.74	SQFT
BALCONY AREA	12.25	SQM	131.90	SQFT
TOTAL AREA	100.70	SQM	1083.60	SQFT

UNIT: 105, 305, 505, 705, 905, 1105

SUITE AREA	88.25	SQM	949.92	SQFT
BALCONY AREA	11.72	SQM	126.20	SQFT
TOTAL AREA	99.97	SQM	1076.10	SQFT

UNIT: 205, 405, 605, 805, 1005

SUITE AREA	88.21	SQM	949.48	SQFT
BALCONY AREA	11.72	SQM	126.20	SQFT
TOTAL AREA	99.93	SQM	1075.60	SQFT



KEY SECTION

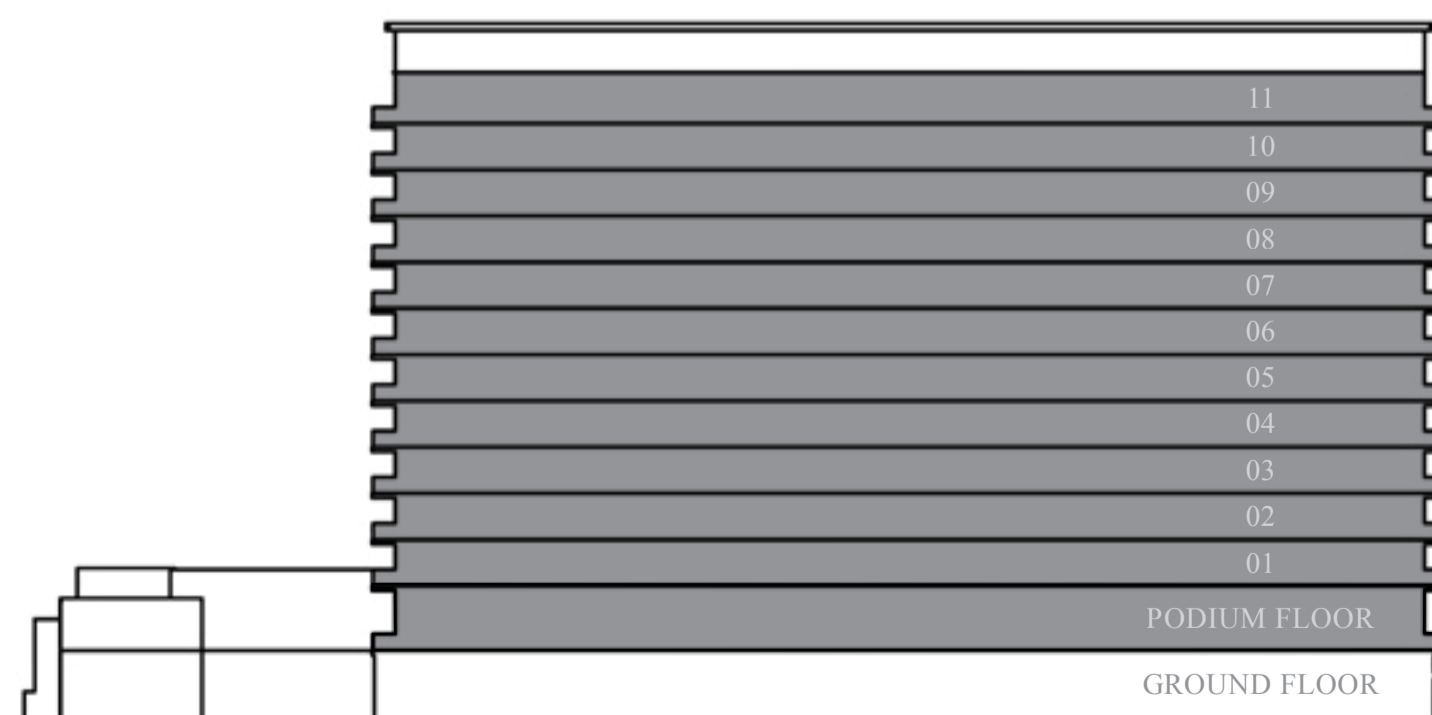

KEY PLANS

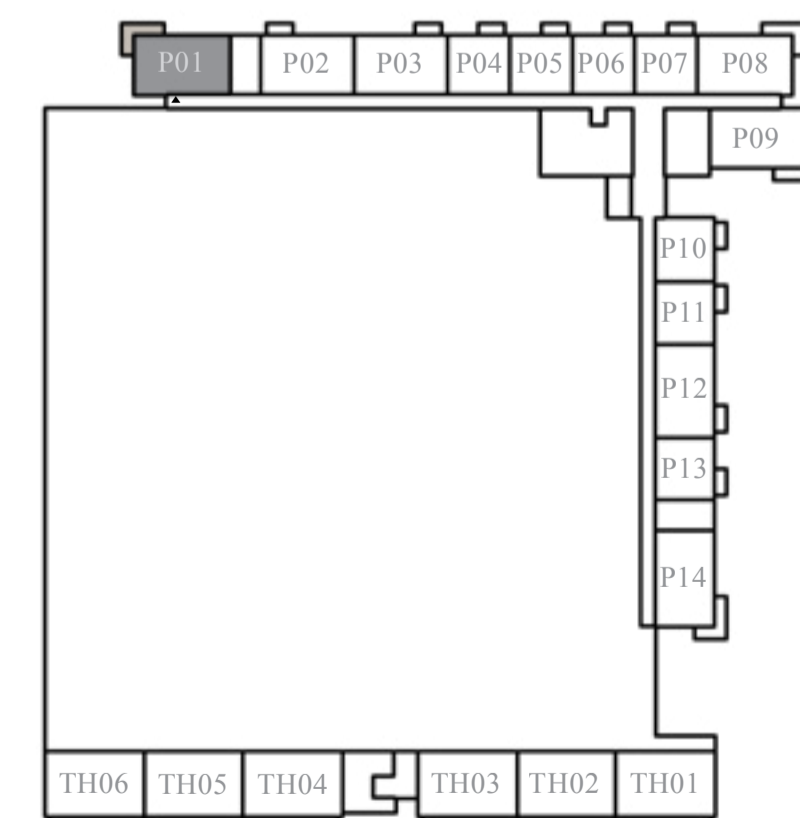

PODIUM FLOOR

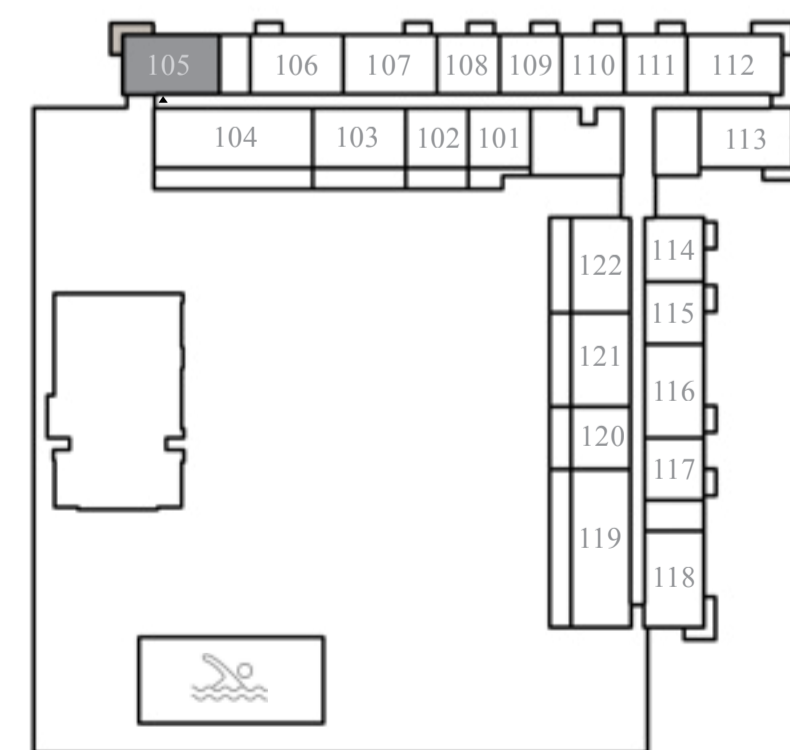

FIRST FLOOR

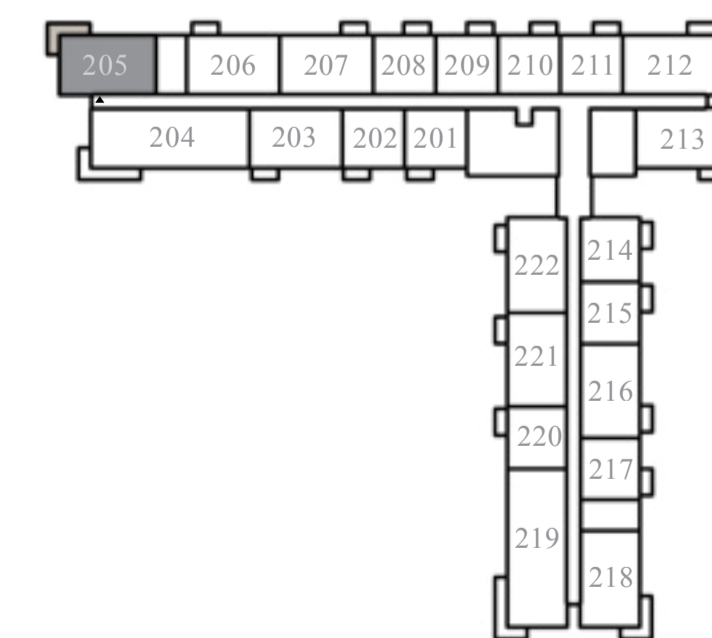

TYPICAL FLOOR (2-11)

FLOOR PLAN 1. All dimensions are in imperial and metric, and measured from finish to finish excluding construction tolerances. 2. All materials, dimensions, and drawings are approximate only. 3. Information is subject to change without notice, at developer's absolute discretion. 4. Actual area may vary from the stated area. 5. Drawings not to scale. 6. All images used are for illustrative purposes only and do not represent the actual size, features, specifications, fittings, and furnishings. 7. The developer reserves the right to make revisions / alterations, at its absolute discretion, without any liability whatsoever.

# golf vale

EMAAR SOUTH

## 2 BEDROOM-TYPE 4

UNIT: 103

SUITE AREA	86.74	SQM	933.66	SQFT
BALCONY AREA	34.30	SQM	368.90	SQFT
TOTAL AREA	121.00	SQM	1302.50	SQFT

UNIT: 121

SUITE AREA	86.98	SQM	936.24	SQFT
BALCONY AREA	34.30	SQM	369.00	SQFT
TOTAL AREA	121.30	SQM	1305.20	SQFT

UNIT: 122

SUITE AREA	87.31	SQM	939.80	SQFT
BALCONY AREA	34.80	SQM	374.30	SQFT
TOTAL AREA	122.10	SQM	1314.10	SQFT



KEY SECTION

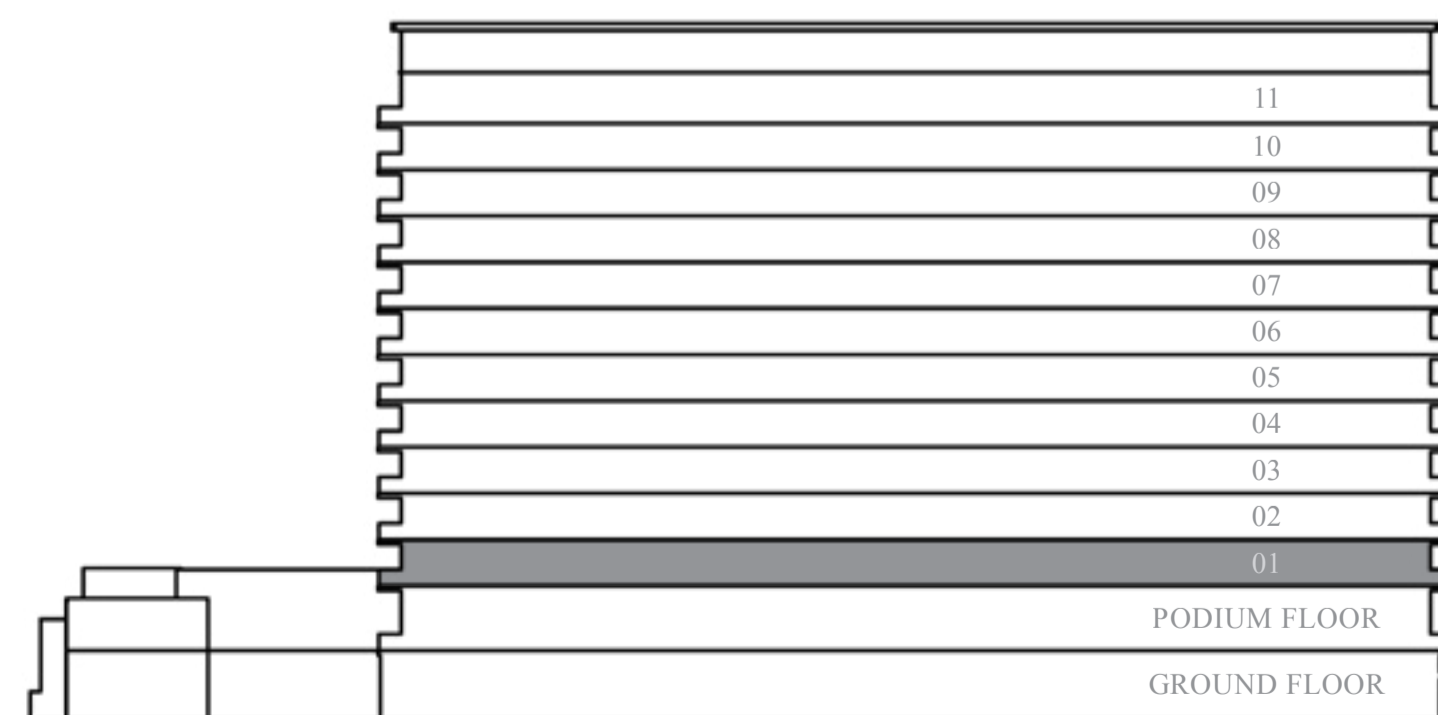

KEY PLANS



FIRST FLOOR

FLOOR PLAN 1. All dimensions are in imperial and metric, and measured from finish to finish excluding construction tolerances. 2. All materials, dimensions, and drawings are approximate only. 3. Information is subject to change without notice, at developer's absolute discretion. 4. Actual area may vary from the stated area. 5. Drawings not to scale. 6. All images used are for illustrative purposes only and do not represent the actual size, features, specifications, fittings, and furnishings. 7. The developer reserves the right to make revisions / alterations, at its absolute discretion, without any liability whatsoever.

# golf vale

EMAAR SOUTH

## 3 BEDROOM-TYPE 1

UNIT: 219, 319, 419, 519, 619, 719, 819, 919, 1019, 1119

SUITE AREA	143.90 SQM	1548.90 SQFT
BALCONY AREA	16.30 SQM	175.20 SQFT
TOTAL AREA	160.20 SQM	1724.20 SQFT



KEY SECTION

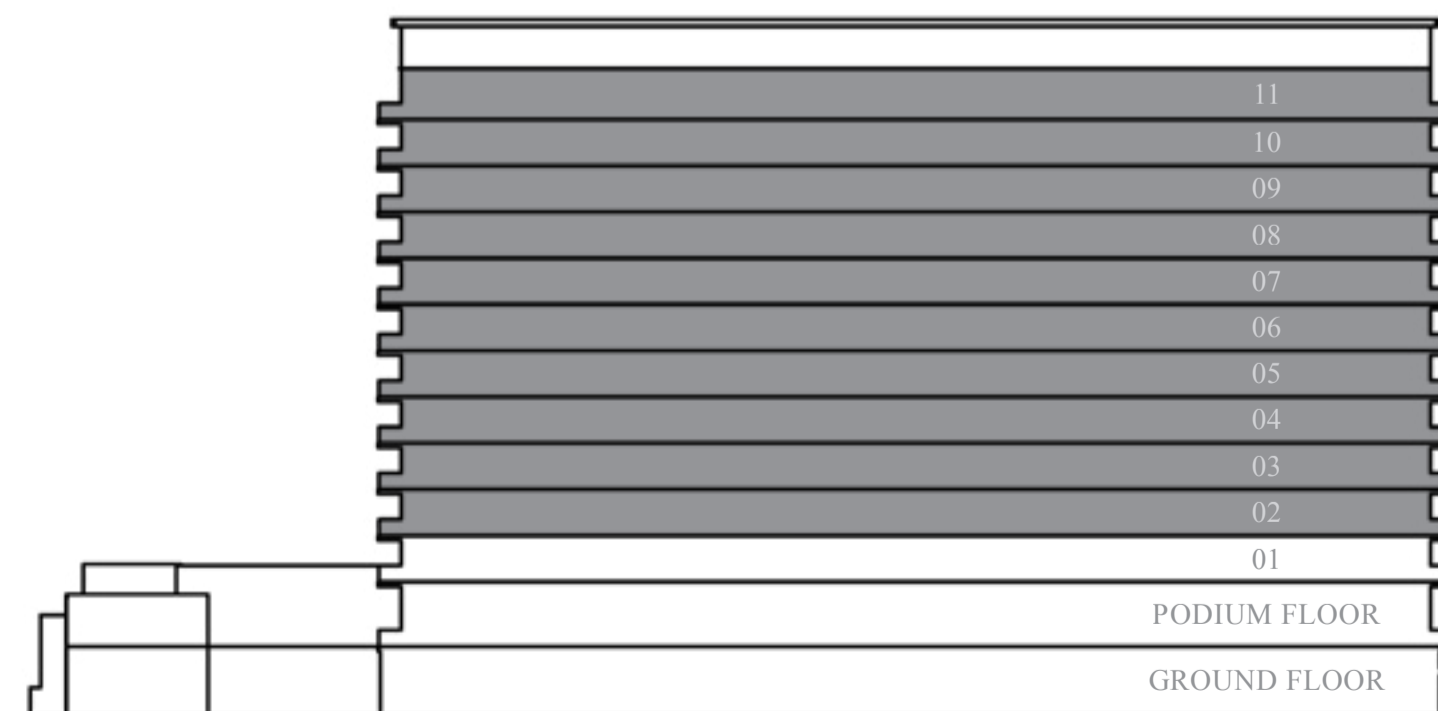

KEY PLANS

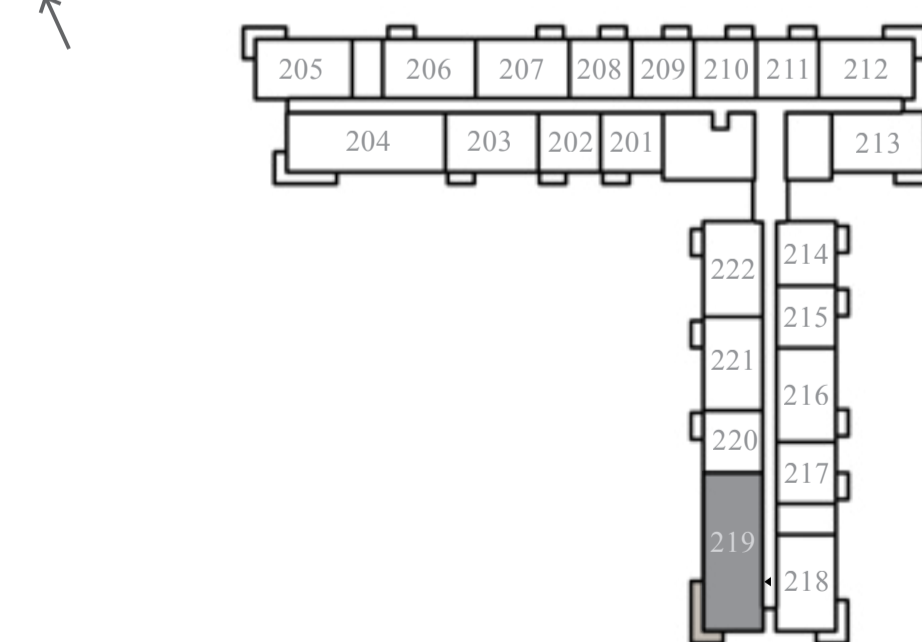

TYPICAL FLOOR (2-11)

FLOOR PLAN 1. All dimensions are in imperial and metric, and measured from finish to finish excluding construction tolerances. 2. All materials, dimensions, and drawings are approximate only. 3. Information is subject to change without notice, at developer's absolute discretion. 4. Actual area may vary from the stated area. 5. Drawings not to scale. 6. All images used are for illustrative purposes only and do not represent the actual size, features, specifications, fittings, and furnishings. 7. The developer reserves the right to make revisions / alterations, at its absolute discretion, without any liability whatsoever.

# golf vale

EMAAR SOUTH

## 3 BEDROOM-TYPE 1A

UNIT: 204, 304, 404, 504, 604, 704, 804, 904, 1004, 1104

SUITE AREA	144.00 SQM	1550.00 SQFT
BALCONY AREA	16.30 SQM	175.20 SQFT
TOTAL AREA	160.30 SQM	1725.20 SQFT



KEY SECTION

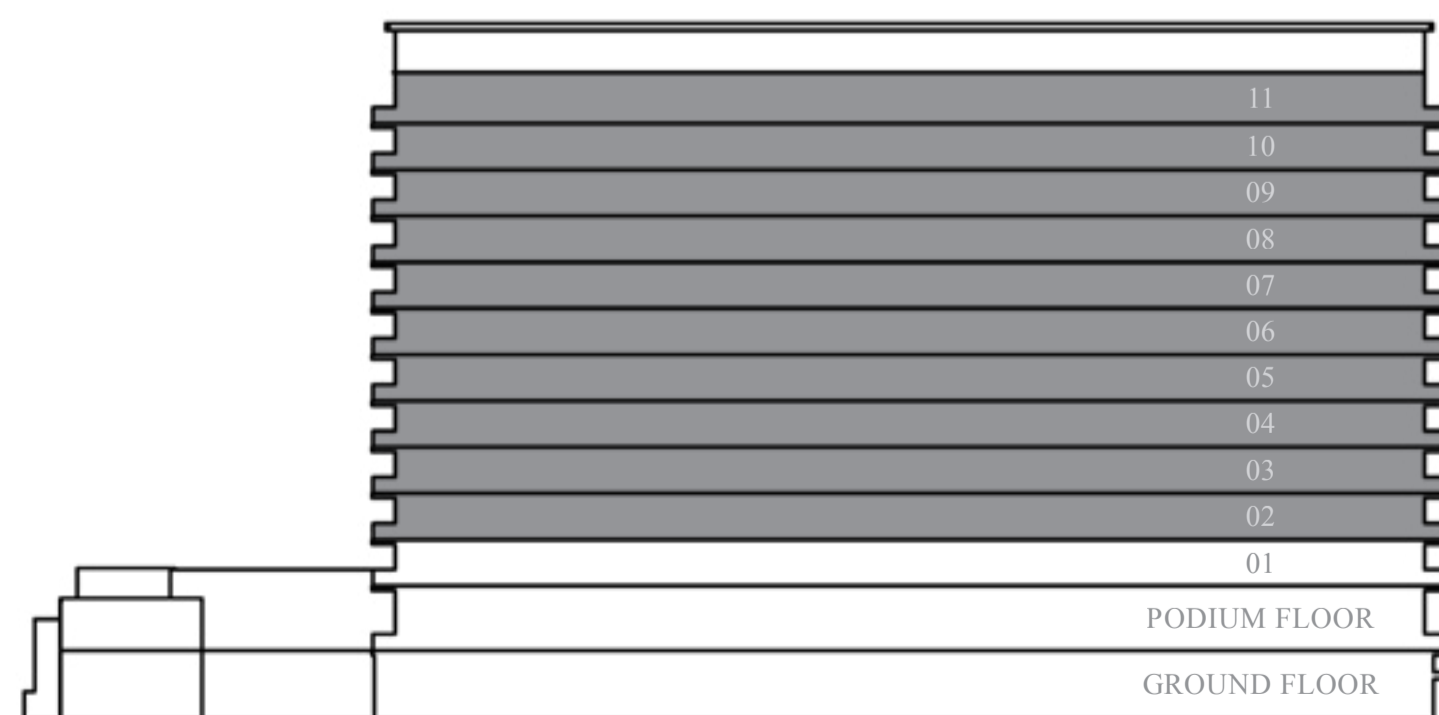

KEY PLANS

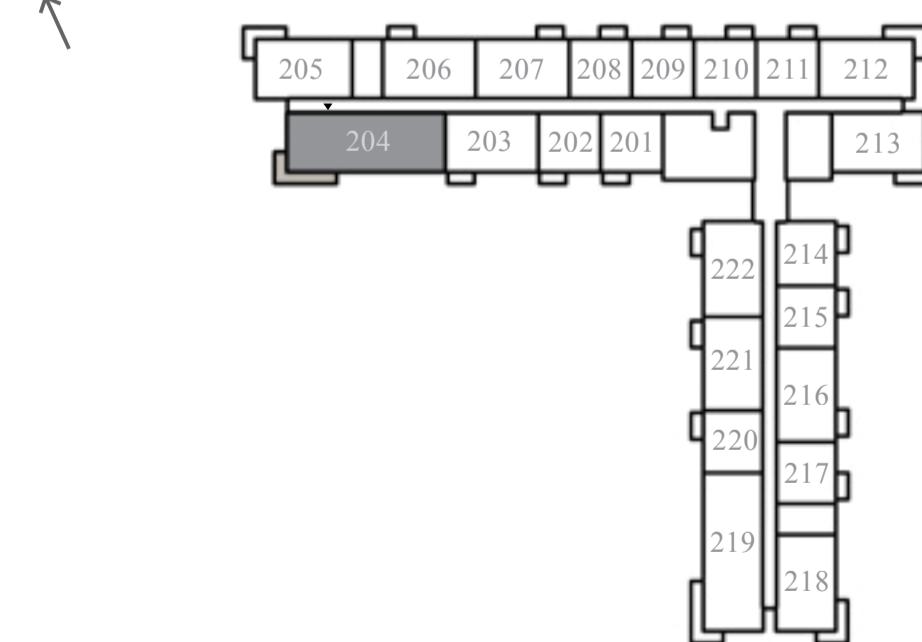

TYPICAL FLOOR (2-11)

FLOOR PLAN 1. All dimensions are in imperial and metric, and measured from finish to finish excluding construction tolerances. 2. All materials, dimensions, and drawings are approximate only. 3. Information is subject to change without notice, at developer's absolute discretion. 4. Actual area may vary from the stated area. 5. Drawings not to scale. 6. All images used are for illustrative purposes only and do not represent the actual size, features, specifications, fittings, and furnishings. 7. The developer reserves the right to make revisions / alterations, at its absolute discretion, without any liability whatsoever.

# golf vale

EMAAR SOUTH

## 3 BEDROOM-TYPE 2

UNIT: 119

SUITE AREA	144.00 SQM	1549.70 SQFT
BALCONY AREA	57.40 SQM	617.30 SQFT
TOTAL AREA	201.30 SQM	2167.00 SQFT

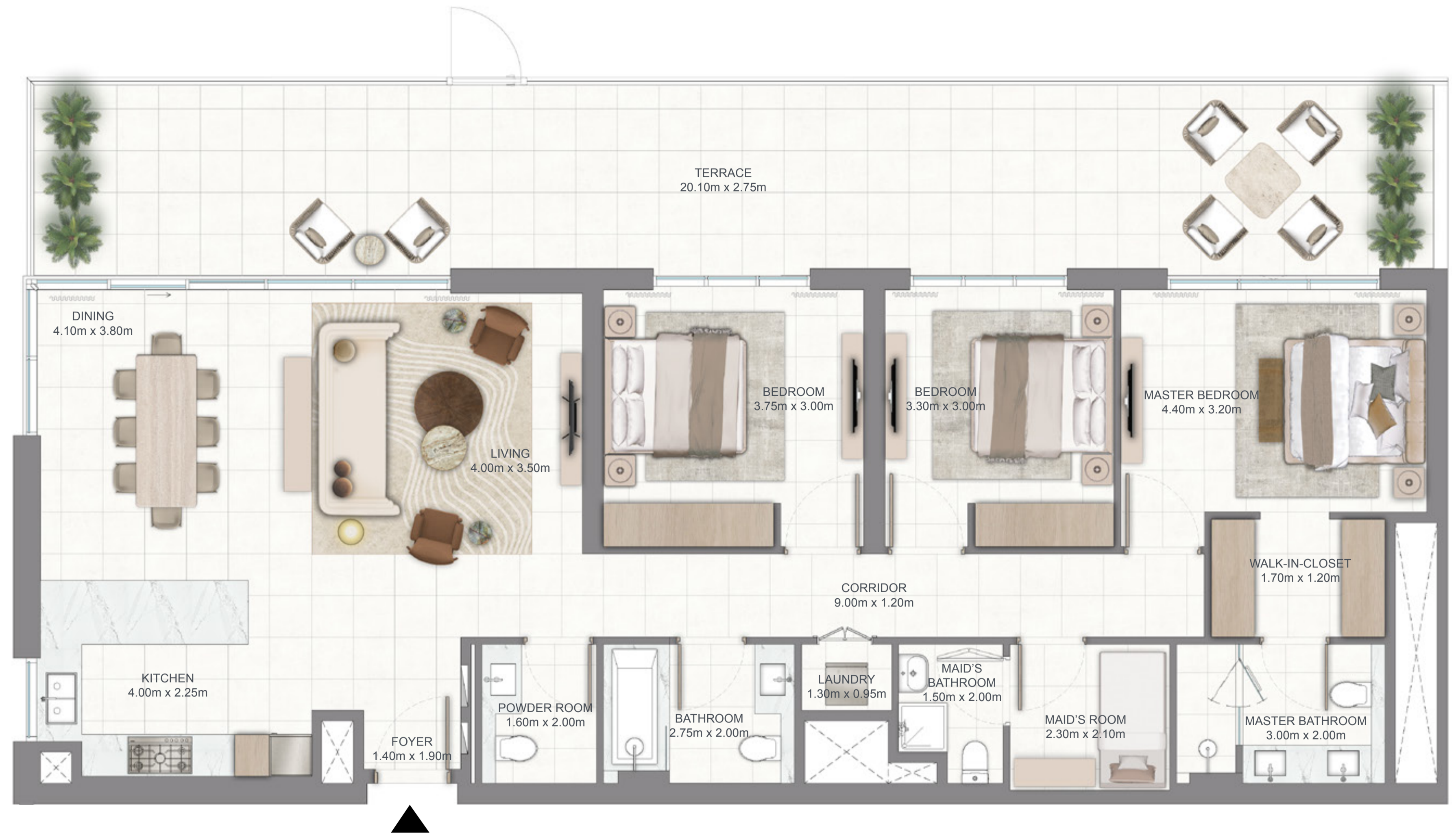

KEY SECTION

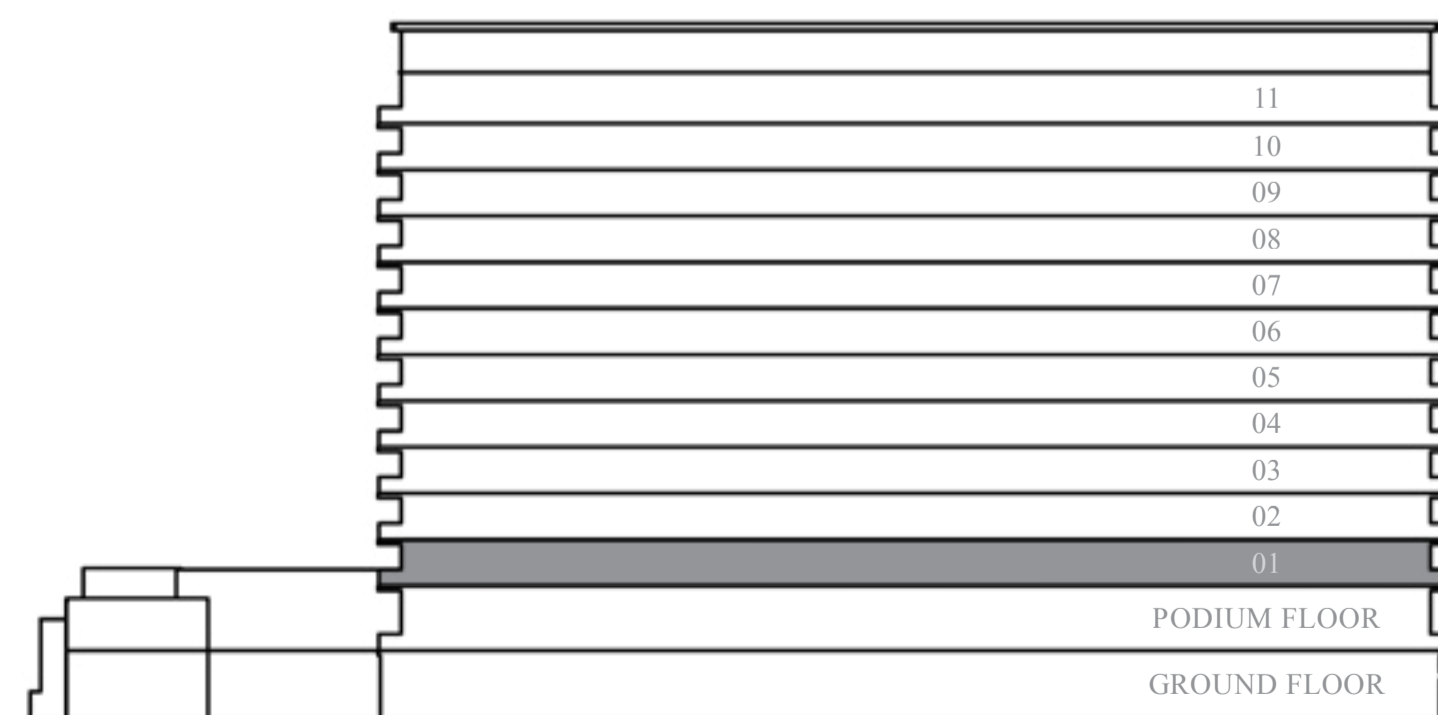

KEY PLANS

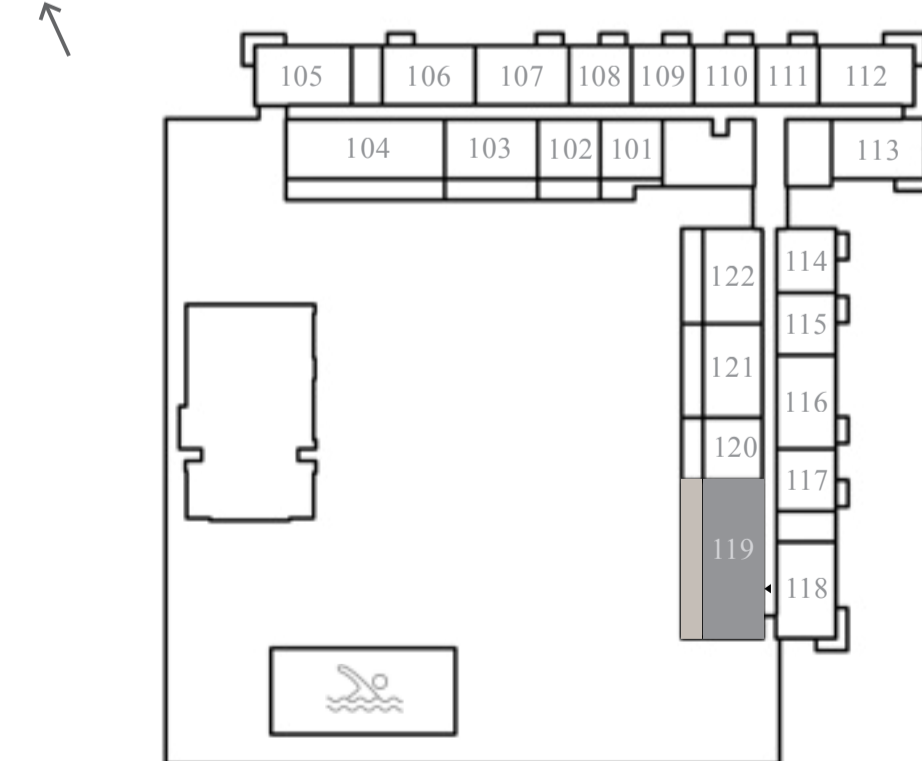

FIRST FLOOR

FLOOR PLAN 1. All dimensions are in imperial and metric, and measured from finish to finish excluding construction tolerances. 2. All materials, dimensions, and drawings are approximate only. 3. Information is subject to change without notice, at developer's absolute discretion. 4. Actual area may vary from the stated area. 5. Drawings not to scale. 6. All images used are for illustrative purposes only and do not represent the actual size, features, specifications, fittings, and furnishings. 7. The developer reserves the right to make revisions / alterations, at its absolute discretion, without any liability whatsoever.

# golf vale

EMAAR SOUTH

## 3 BEDROOM-TYPE 2A

UNIT: 104

SUITE AREA	144.00 SQM	1549.70 SQFT
BALCONY AREA	57.40 SQM	617.40 SQFT
TOTAL AREA	201.30 SQM	2167.10 SQFT



KEY SECTION

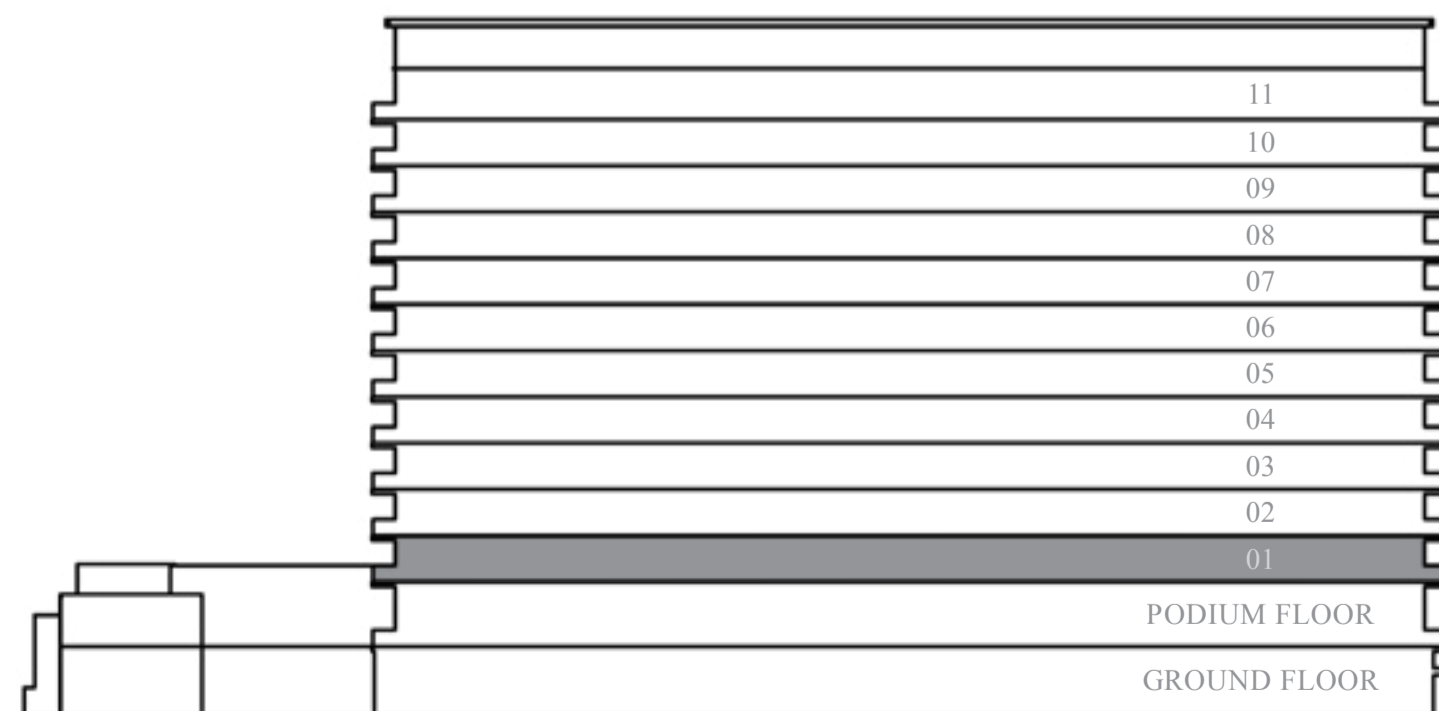

KEY PLANS

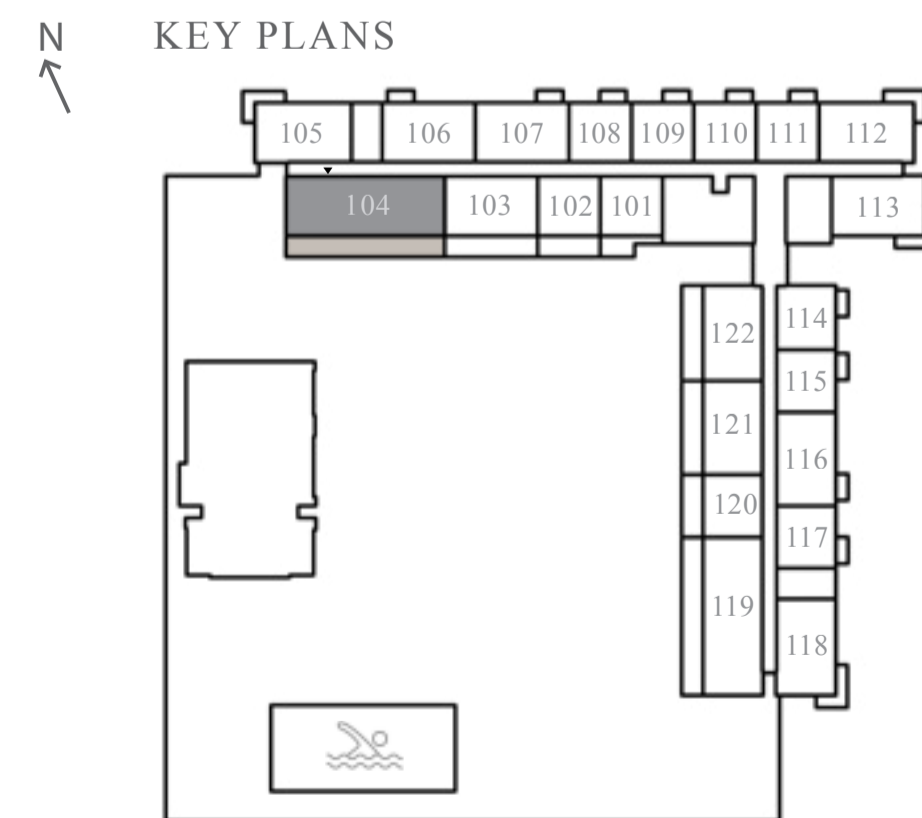

FIRST FLOOR

FLOOR PLAN 1. All dimensions are in imperial and metric, and measured from finish to finish excluding construction tolerances. 2. All materials, dimensions, and drawings are approximate only. 3. Information is subject to change without notice, at developer's absolute discretion. 4. Actual area may vary from the stated area. 5. Drawings not to scale. 6. All images used are for illustrative purposes only and do not represent the actual size, features, specifications, fittings, and furnishings. 7. The developer reserves the right to make revisions / alterations, at its absolute discretion, without any liability whatsoever.

# golf vale

EMAAR SOUTH

## TOWNHOUSE-TYPE 1

UNIT: TH-02

SUITE AREA	202.00 SQM	2174.20 SQFT
BALCONY AREA	59.60 SQM	641.40 SQFT
TOTAL AREA	261.60 SQM	2815.60 SQFT



LOWER FLOOR

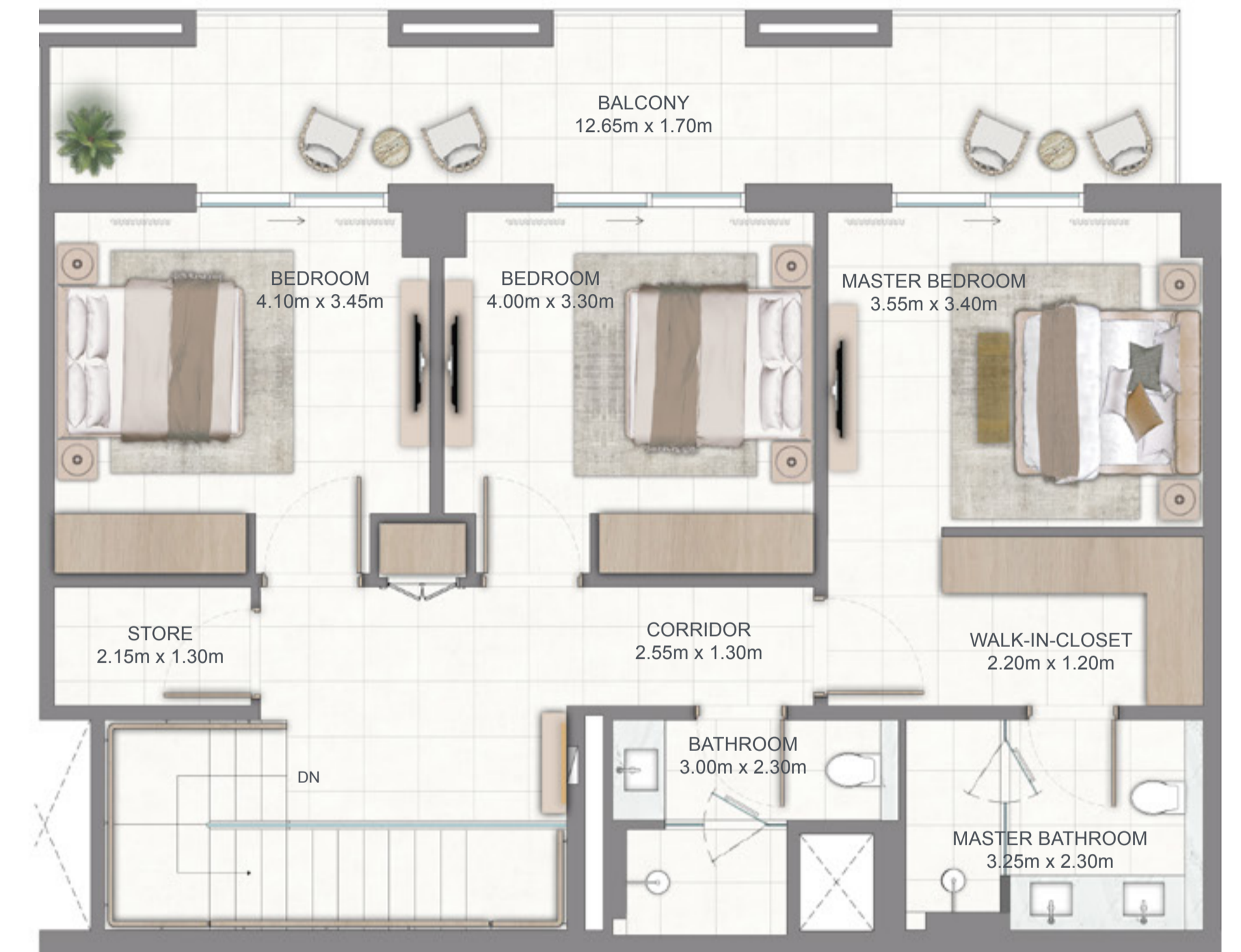

UPPER FLOOR

KEY SECTION

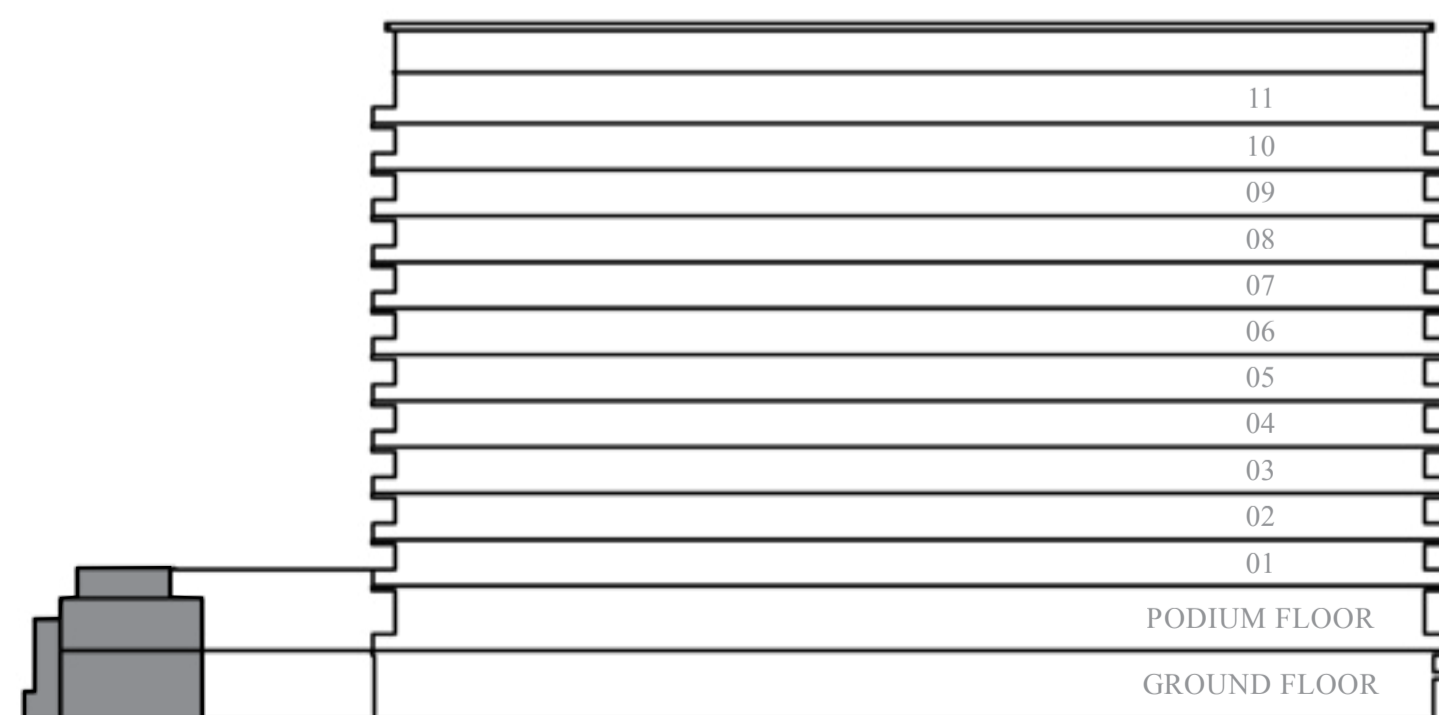

KEY PLANS



GROUND FLOOR

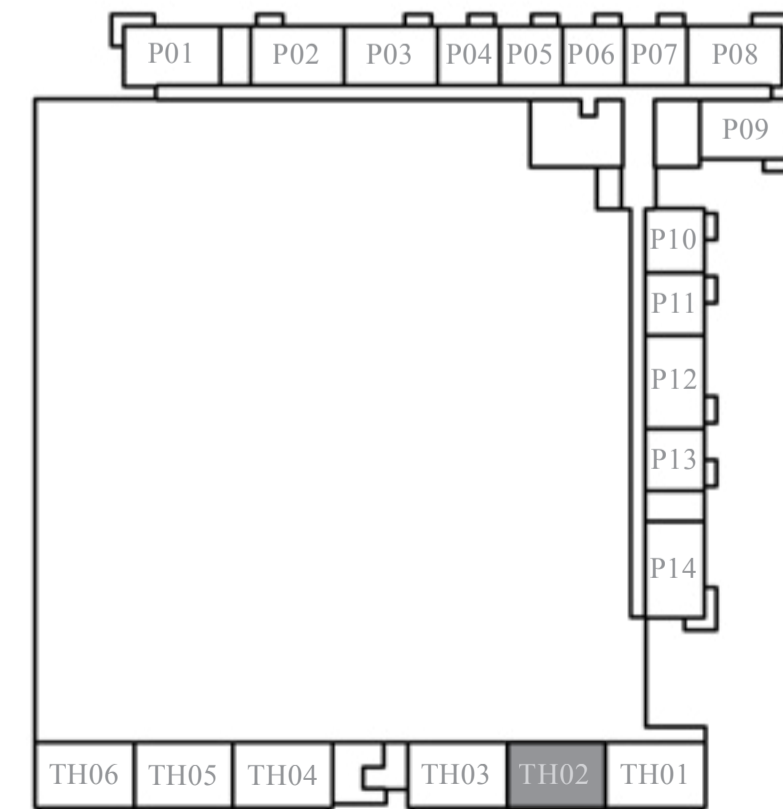

PODIUM FLOOR

FLOOR PLAN 1. All dimensions are in imperial and metric, and measured from finish to finish excluding construction tolerances. 2. All materials, dimensions, and drawings are approximate only. 3. Information is subject to change without notice, at developer's absolute discretion. 4. Actual area may vary from the stated area. 5. Drawings not to scale. 6. All images used are for illustrative purposes only and do not represent the actual size, features, specifications, fittings, and furnishings. 7. The developer reserves the right to make revisions / alterations, at its absolute discretion, without any liability whatsoever.

# golf vale

EMAAR SOUTH

## TOWNHOUSE-TYPE 1

UNIT: TH-04

SUITE AREA	202.20 SQM	2175.90 SQFT
BALCONY AREA	57.00 SQM	613.50 SQFT
TOTAL AREA	259.20 SQM	2789.50 SQFT



LOWER FLOOR

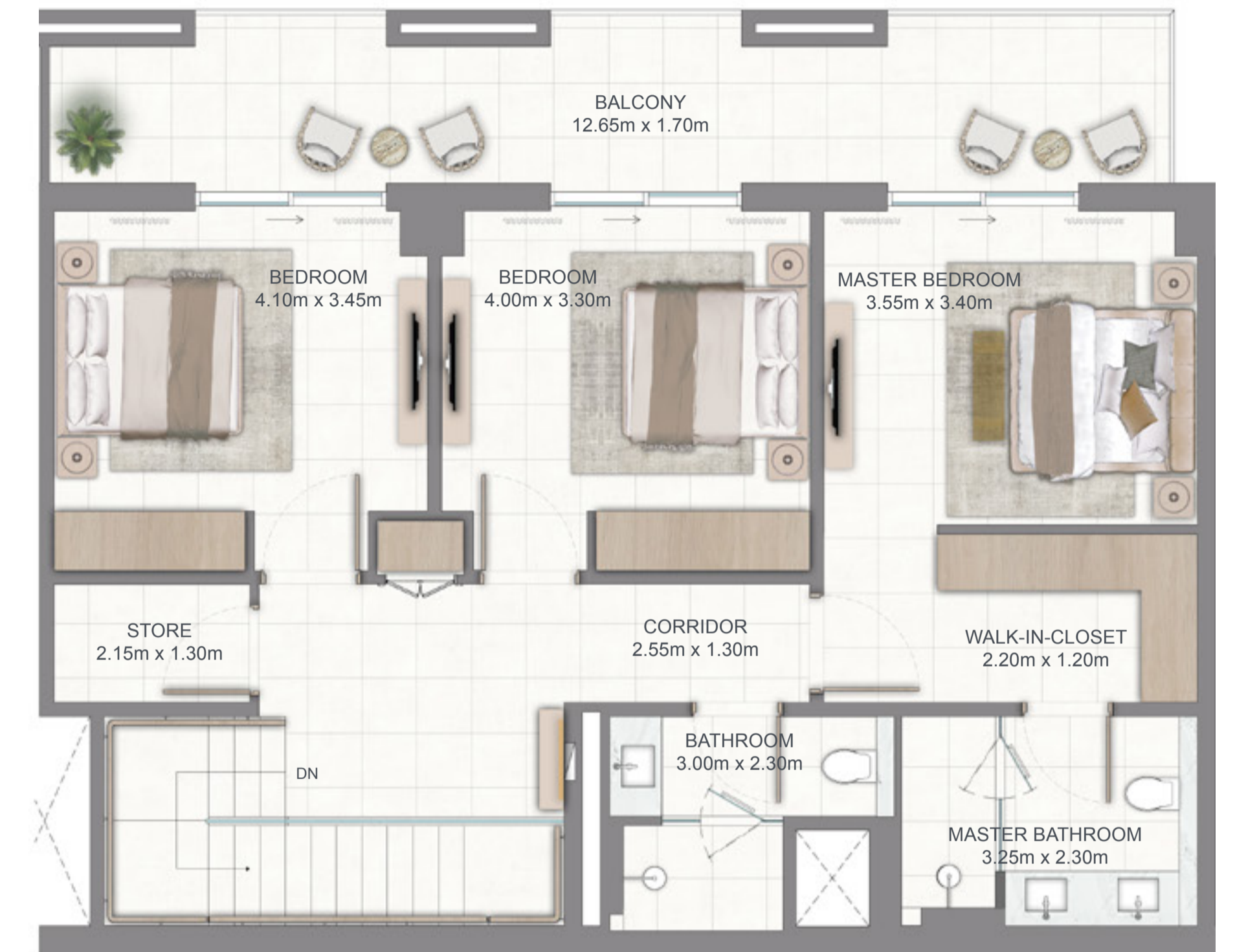

UPPER FLOOR

KEY SECTION

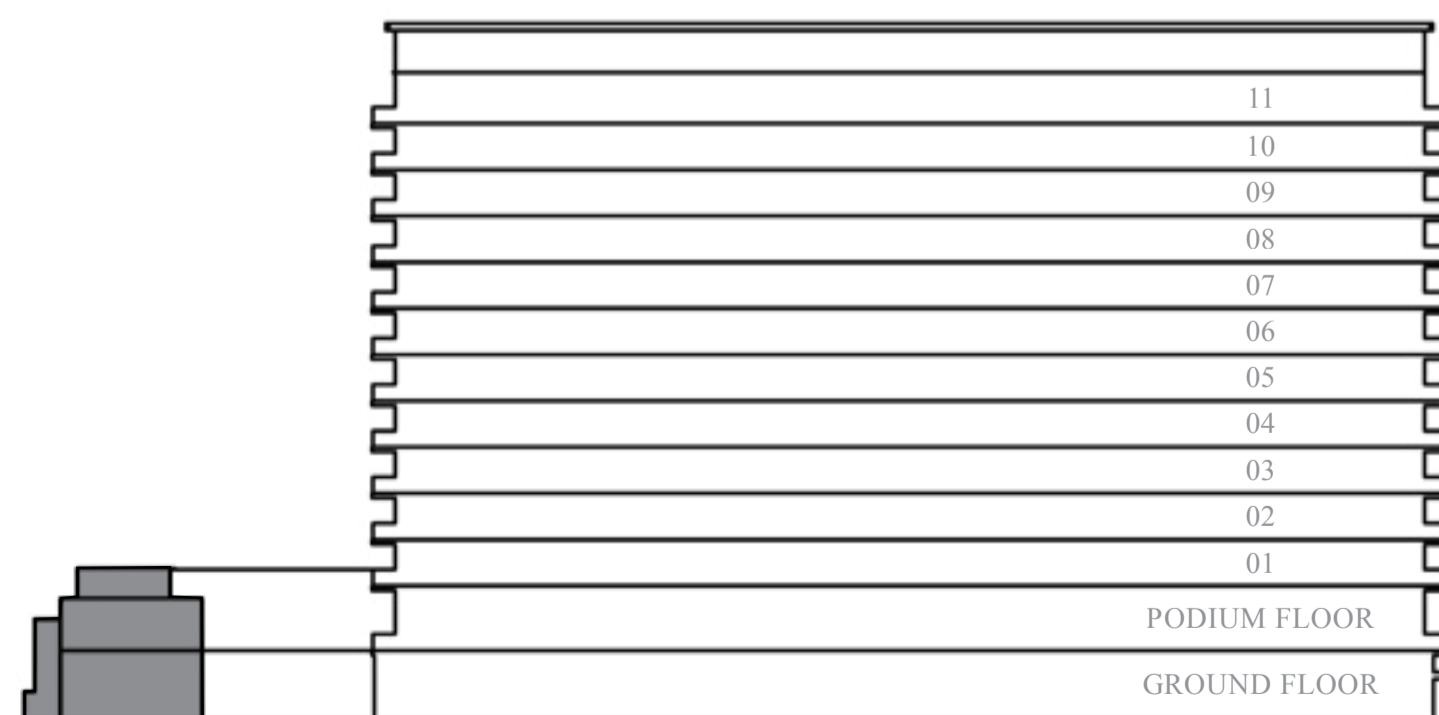

KEY PLANS

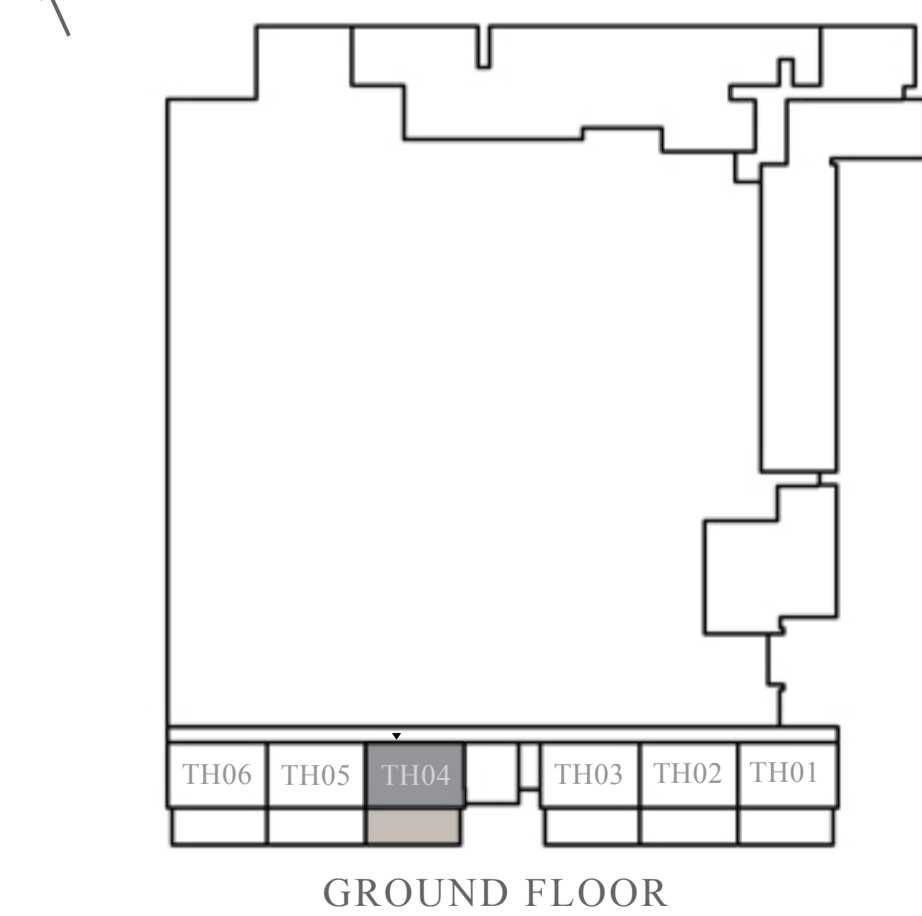

GROUND FLOOR

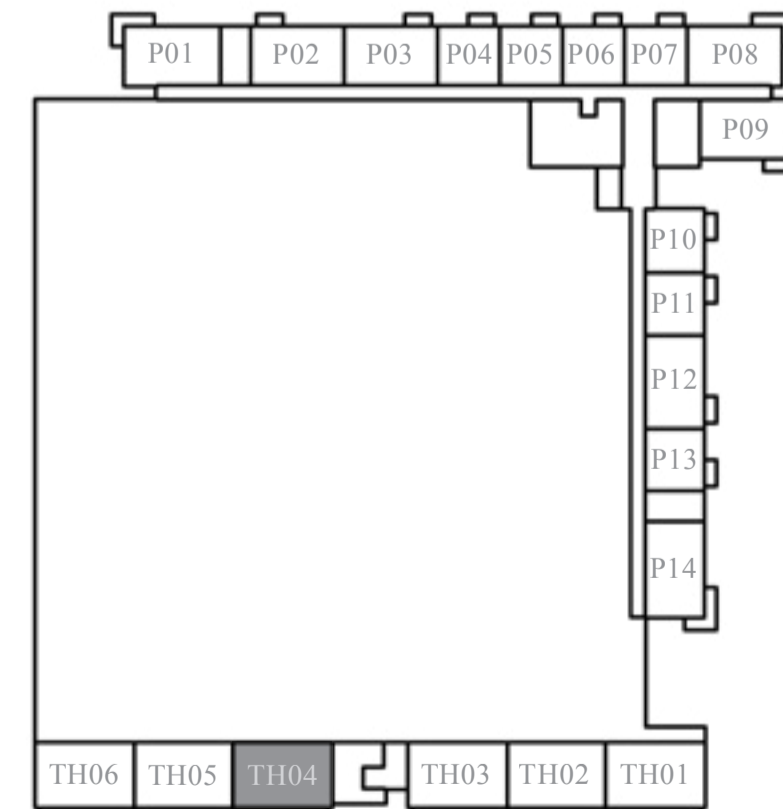

PODIUM FLOOR

FLOOR PLAN 1. All dimensions are in imperial and metric, and measured from finish to finish excluding construction tolerances. 2. All materials, dimensions, and drawings are approximate only. 3. Information is subject to change without notice, at developer's absolute discretion. 4. Actual area may vary from the stated area. 5. Drawings not to scale. 6. All images used are for illustrative purposes only and do not represent the actual size, features, specifications, fittings, and furnishings. 7. The developer reserves the right to make revisions / alterations, at its absolute discretion, without any liability whatsoever.

# golf vale

EMAAR SOUTH

## TOWNHOUSE-TYPE 1

UNIT: TH-06

SUITE AREA	202.80 SQM	2183.00 SQFT
BALCONY AREA	57.00 SQM	613.20 SQFT
TOTAL AREA	259.80 SQM	2796.30 SQFT



LOWER FLOOR

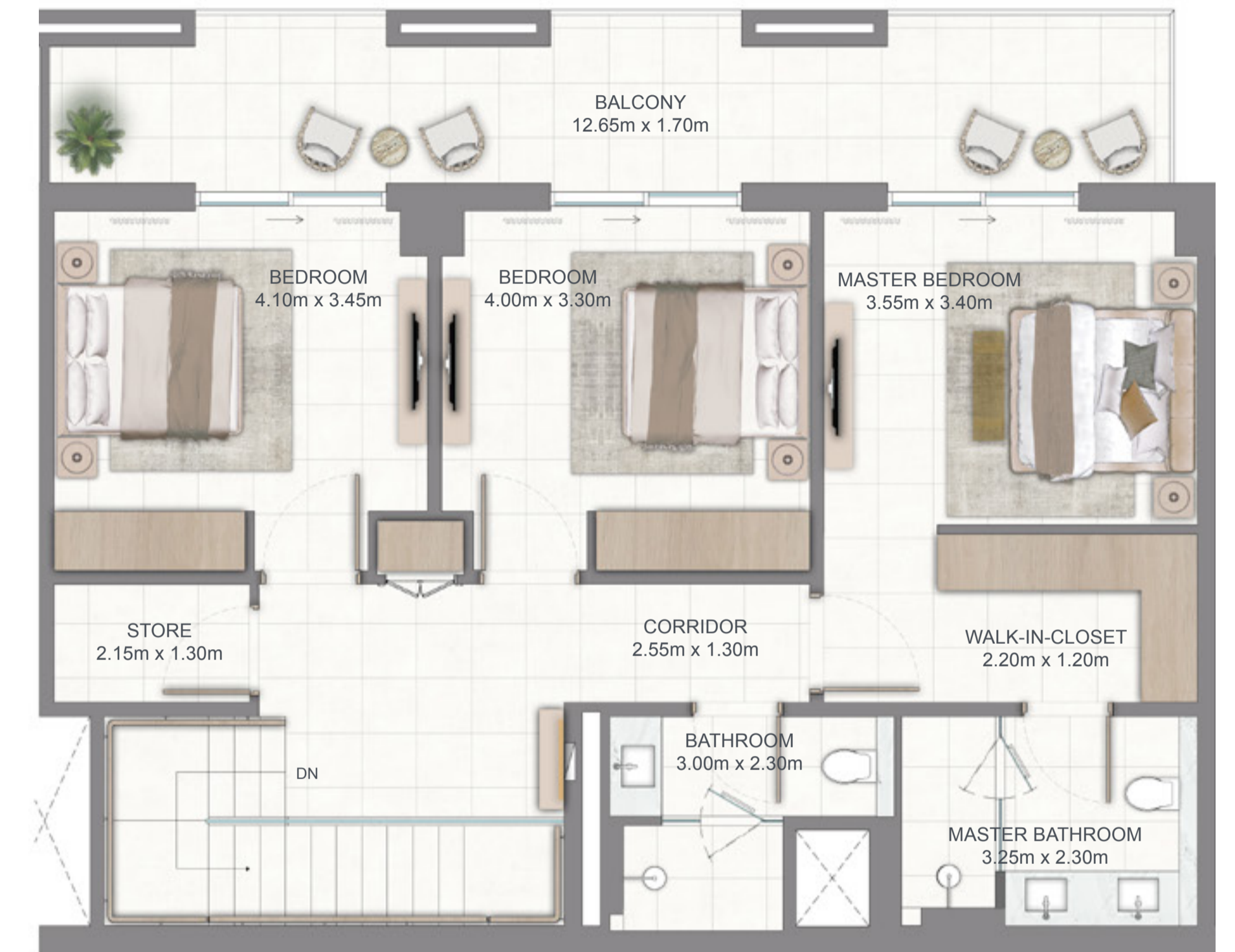

UPPER FLOOR

KEY SECTION

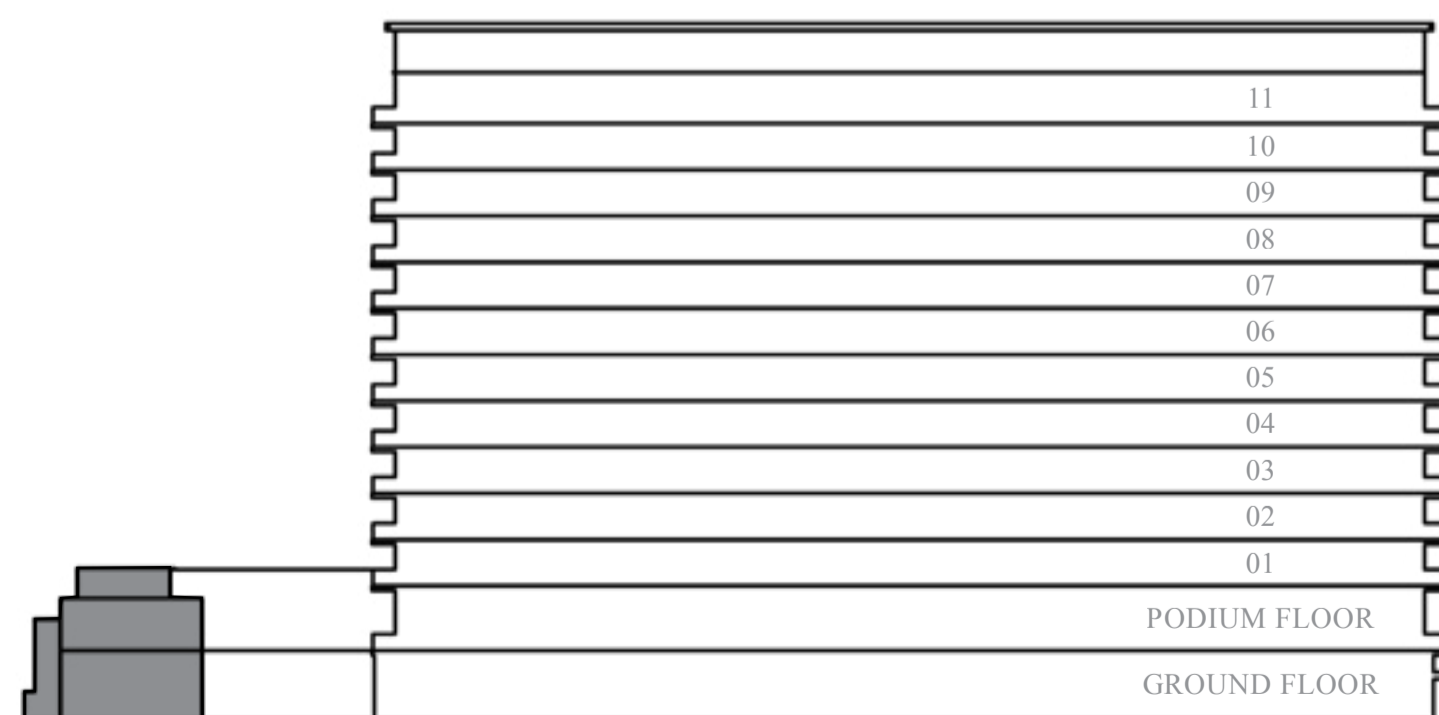

KEY PLANS

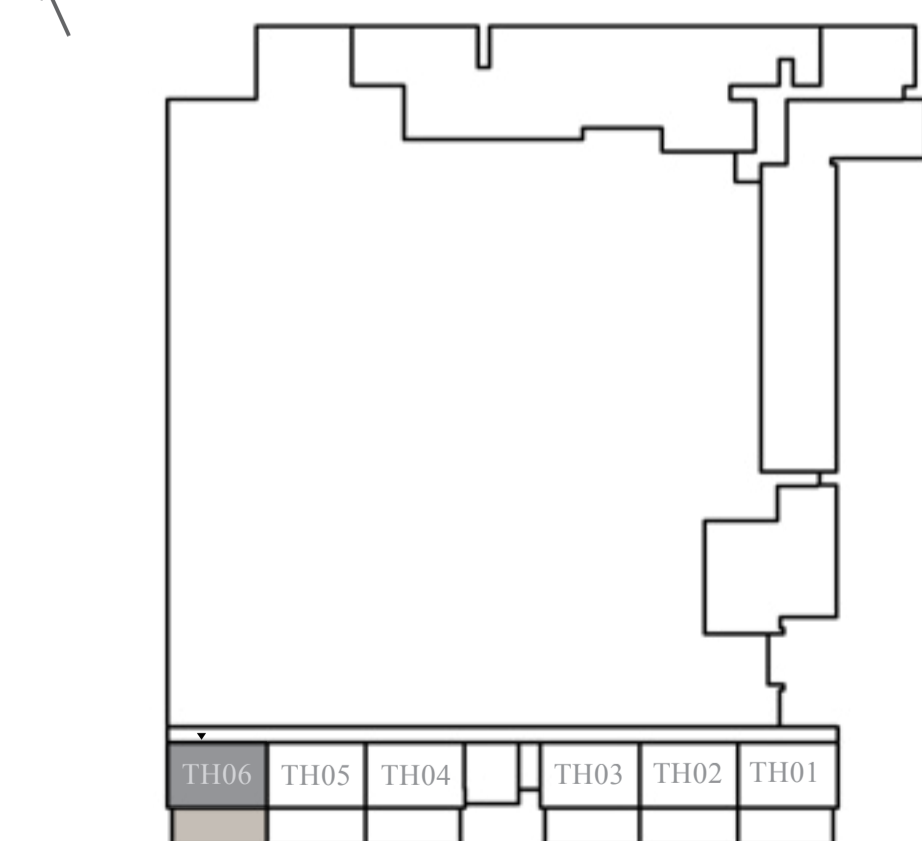

GROUND FLOOR

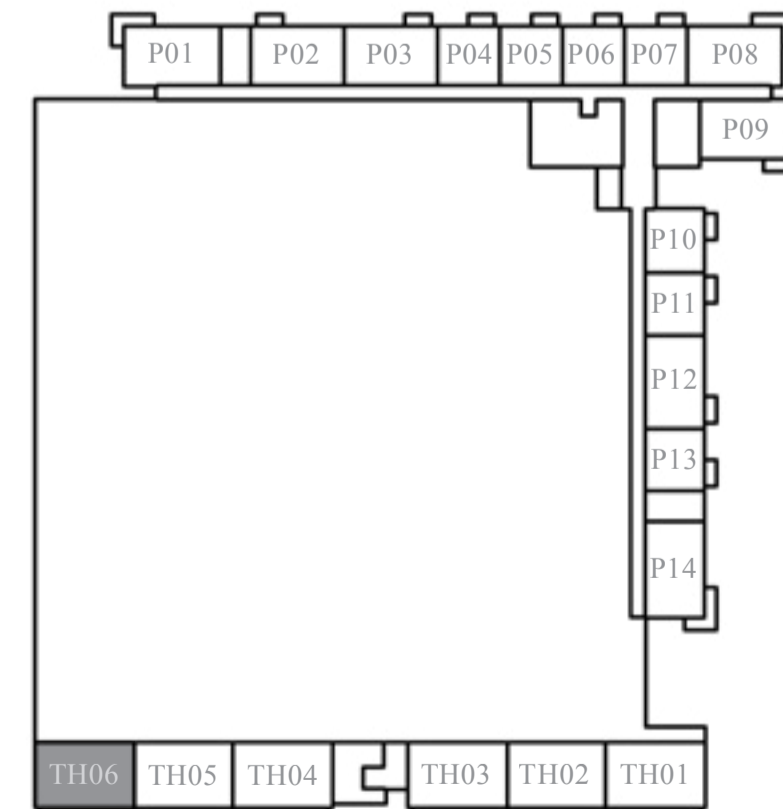

PODIUM FLOOR

FLOOR PLAN 1. All dimensions are in imperial and metric, and measured from finish to finish excluding construction tolerances. 2. All materials, dimensions, and drawings are approximate only. 3. Information is subject to change without notice, at developer's absolute discretion. 4. Actual area may vary from the stated area. 5. Drawings not to scale. 6. All images used are for illustrative purposes only and do not represent the actual size, features, specifications, fittings, and furnishings. 7. The developer reserves the right to make revisions / alterations, at its absolute discretion, without any liability whatsoever.

# golf vale

EMAAR SOUTH

## TOWNHOUSE-TYPE 1A

UNIT: TH-01

SUITE AREA	202.80 SQM	2183.00 SQFT
BALCONY AREA	57.00 SQM	613.20 SQFT
TOTAL AREA	259.80 SQM	2796.30 SQFT

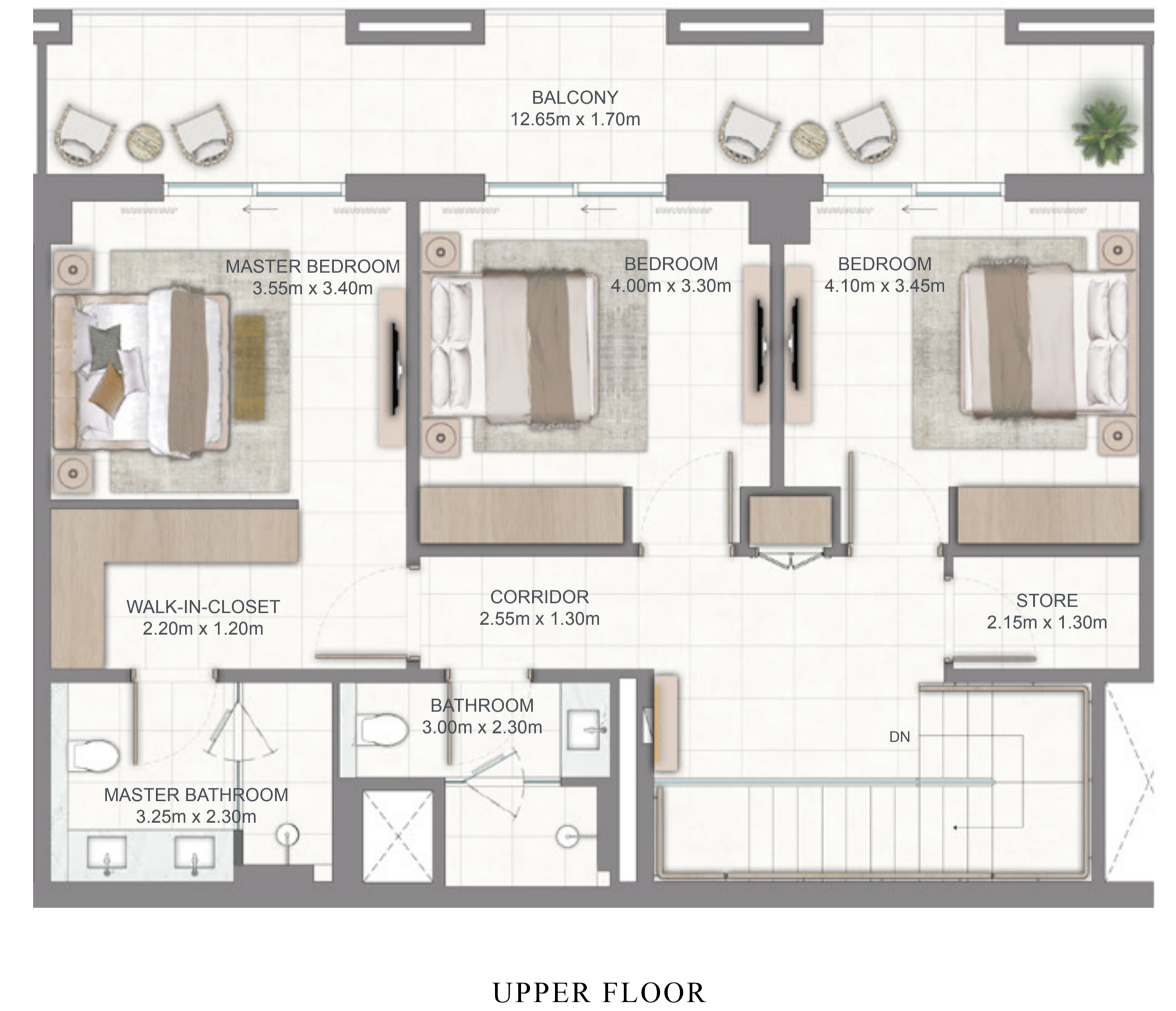

KEY SECTION

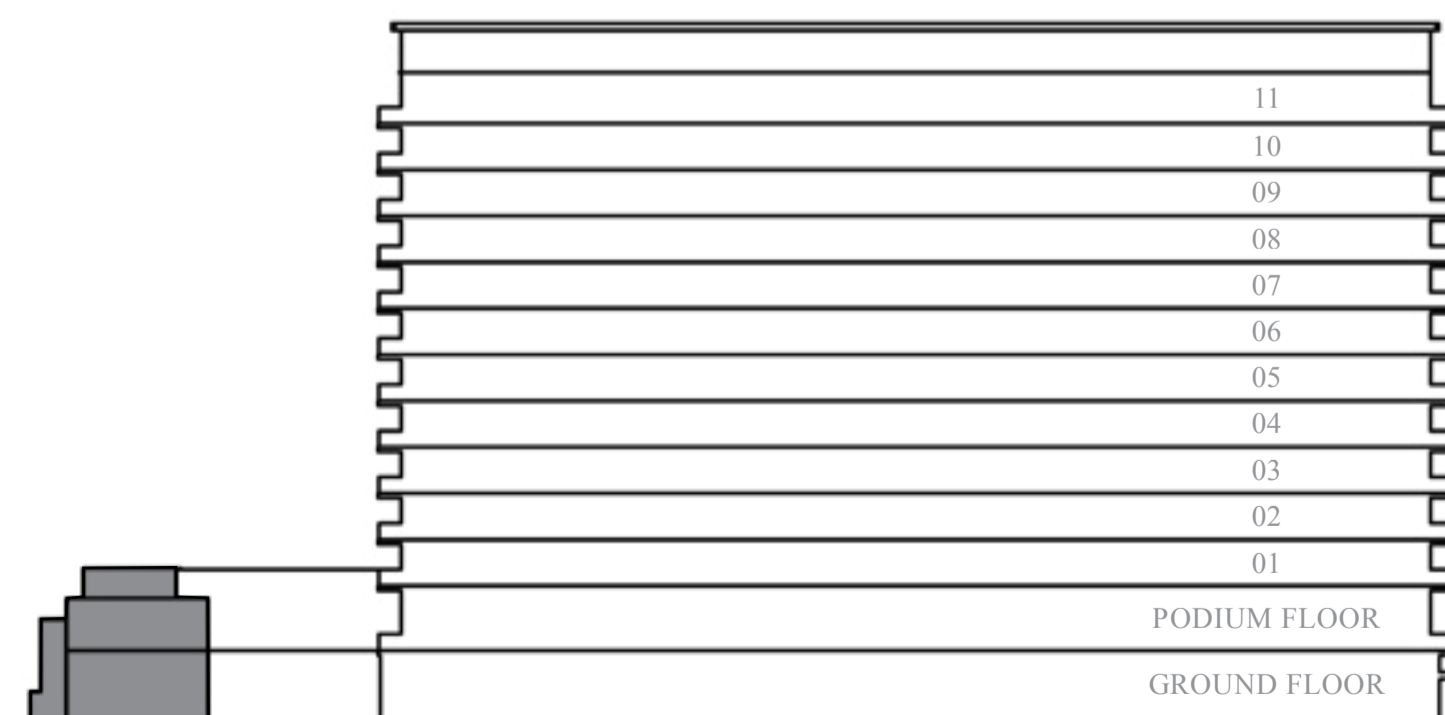

KEY PLANS



FLOOR PLAN 1. All dimensions are in imperial and metric, and measured from finish to finish excluding construction tolerances. 2. All materials, dimensions, and drawings are approximate only. 3. Information is subject to change without notice, at developer's absolute discretion. 4. Actual area may vary from the stated area. 5. Drawings not to scale. 6. All images used are for illustrative purposes only and do not represent the actual size, features, specifications, fittings, and furnishings. 7. The developer reserves the right to make revisions / alterations, at its absolute discretion, without any liability whatsoever.

# golf vale

EMAAR SOUTH

## TOWNHOUSE-TYPE 1A

UNIT: TH-03

SUITE AREA	203.00 SQM	2185.50 SQFT
BALCONY AREA	57.00 SQM	613.50 SQFT
TOTAL AREA	260.00 SQM	2799.10 SQFT



LOWER FLOOR

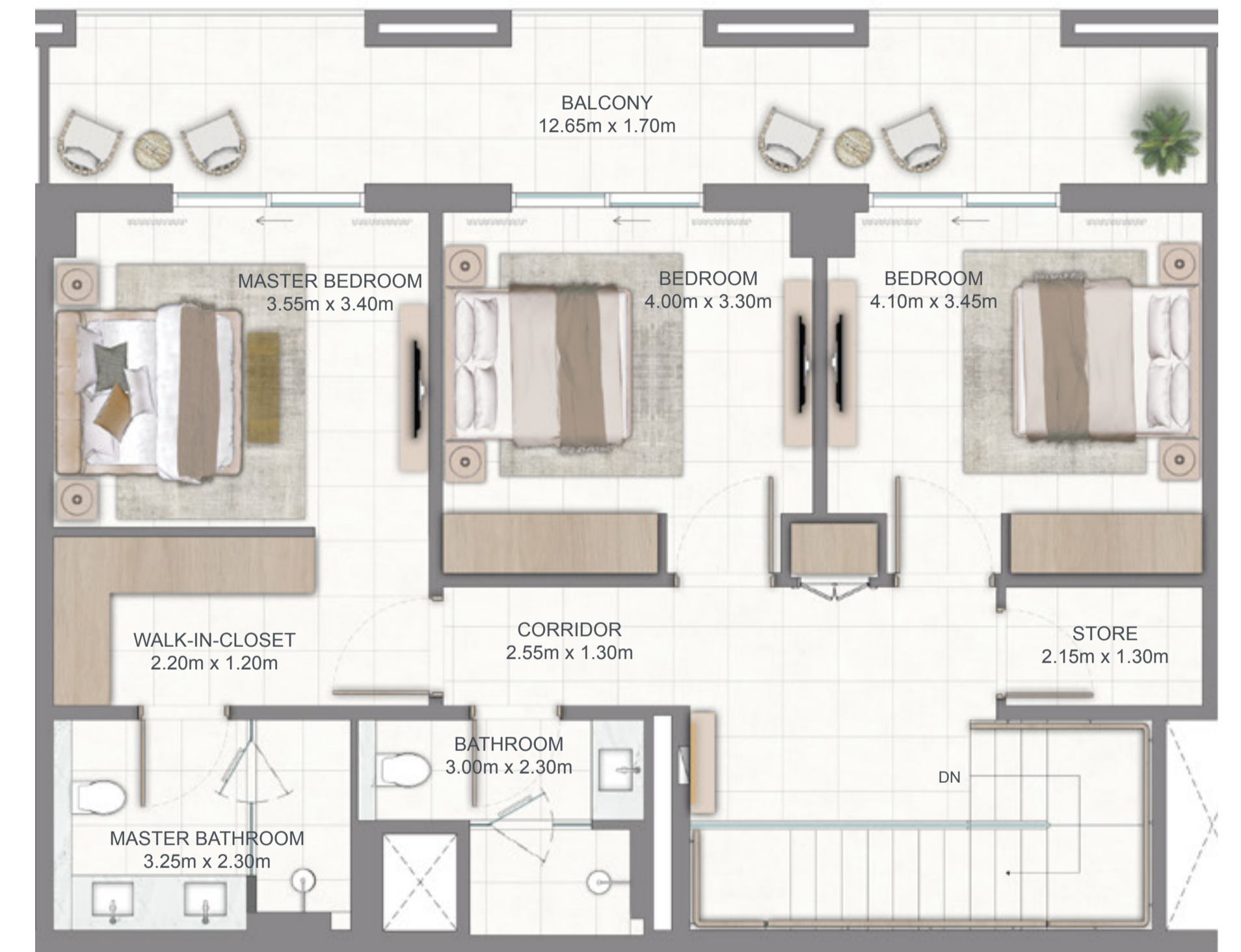

UPPER FLOOR

KEY SECTION

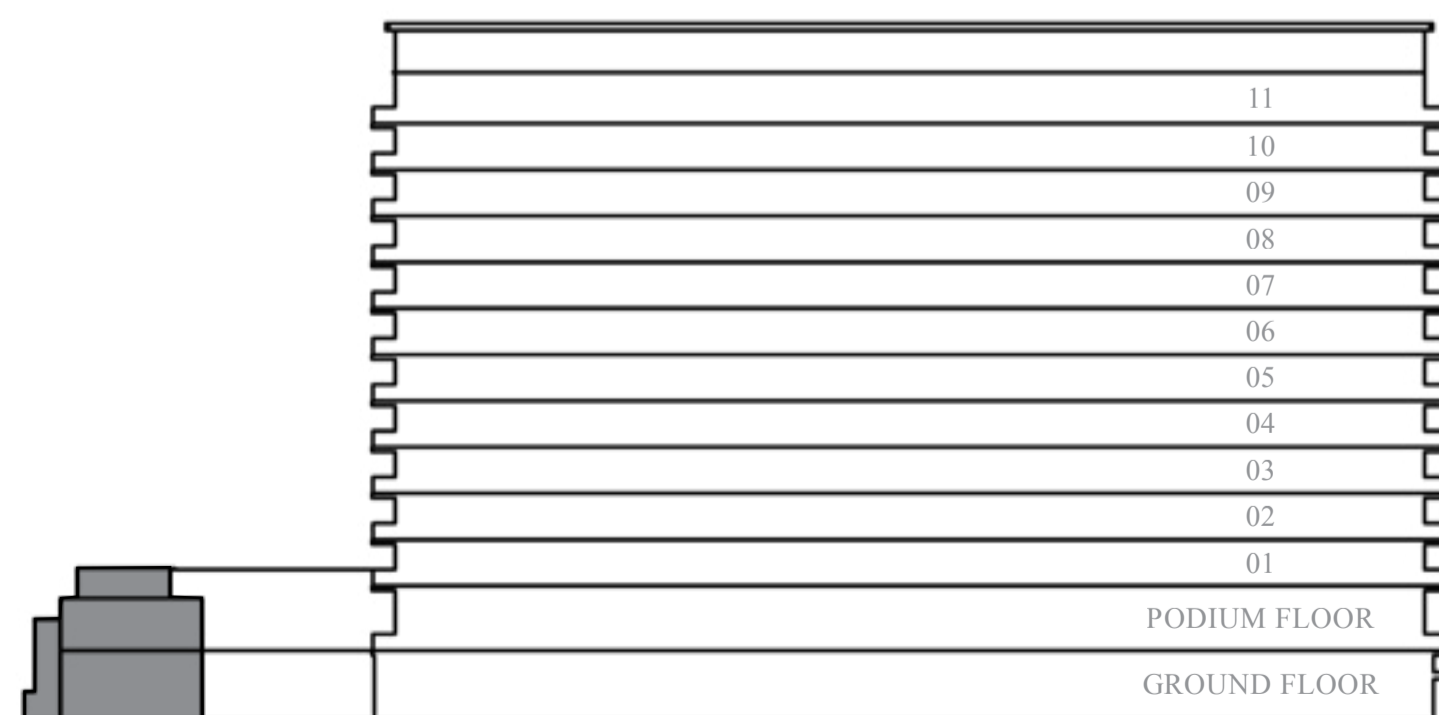

KEY PLANS

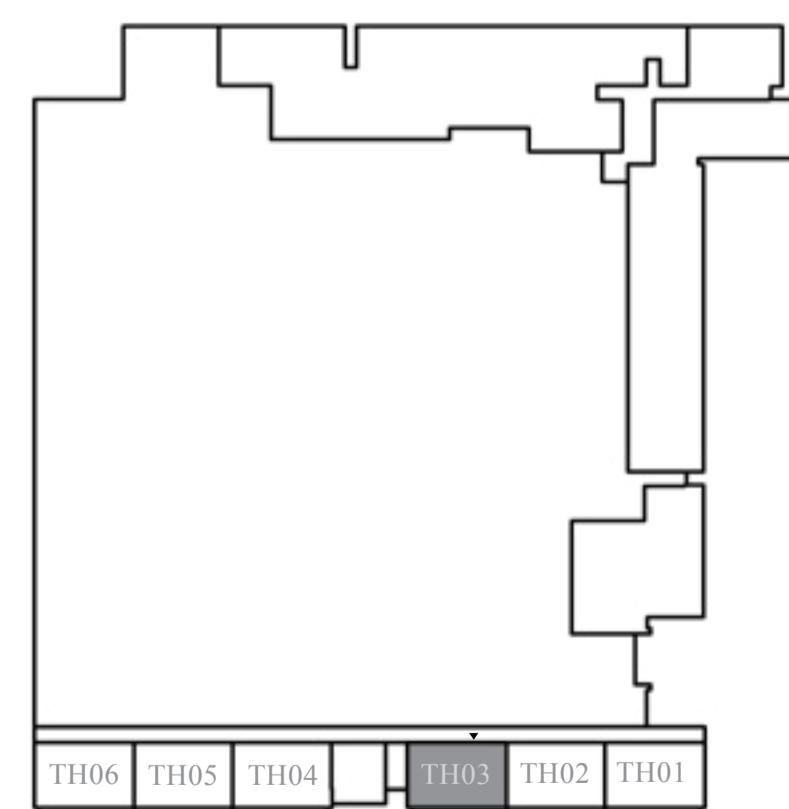

GROUND FLOOR

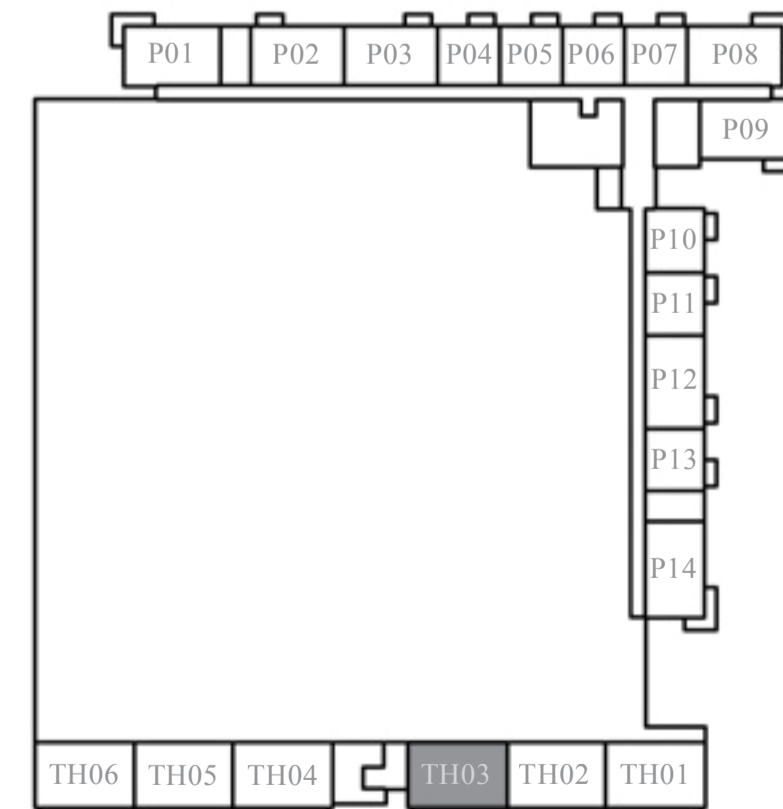

PODIUM FLOOR

FLOOR PLAN 1. All dimensions are in imperial and metric, and measured from finish to finish excluding construction tolerances. 2. All materials, dimensions, and drawings are approximate only. 3. Information is subject to change without notice, at developer's absolute discretion. 4. Actual area may vary from the stated area. 5. Drawings not to scale. 6. All images used are for illustrative purposes only and do not represent the actual size, features, specifications, fittings, and furnishings. 7. The developer reserves the right to make revisions / alterations, at its absolute discretion, without any liability whatsoever.

# golf vale

EMAAR SOUTH

## TOWNHOUSE-TYPE 1A

UNIT: TH-05

SUITE AREA	202.00 SQM	2174.30 SQFT
BALCONY AREA	59.60 SQM	641.30 SQFT
TOTAL AREA	261.60 SQM	2815.60 SQFT

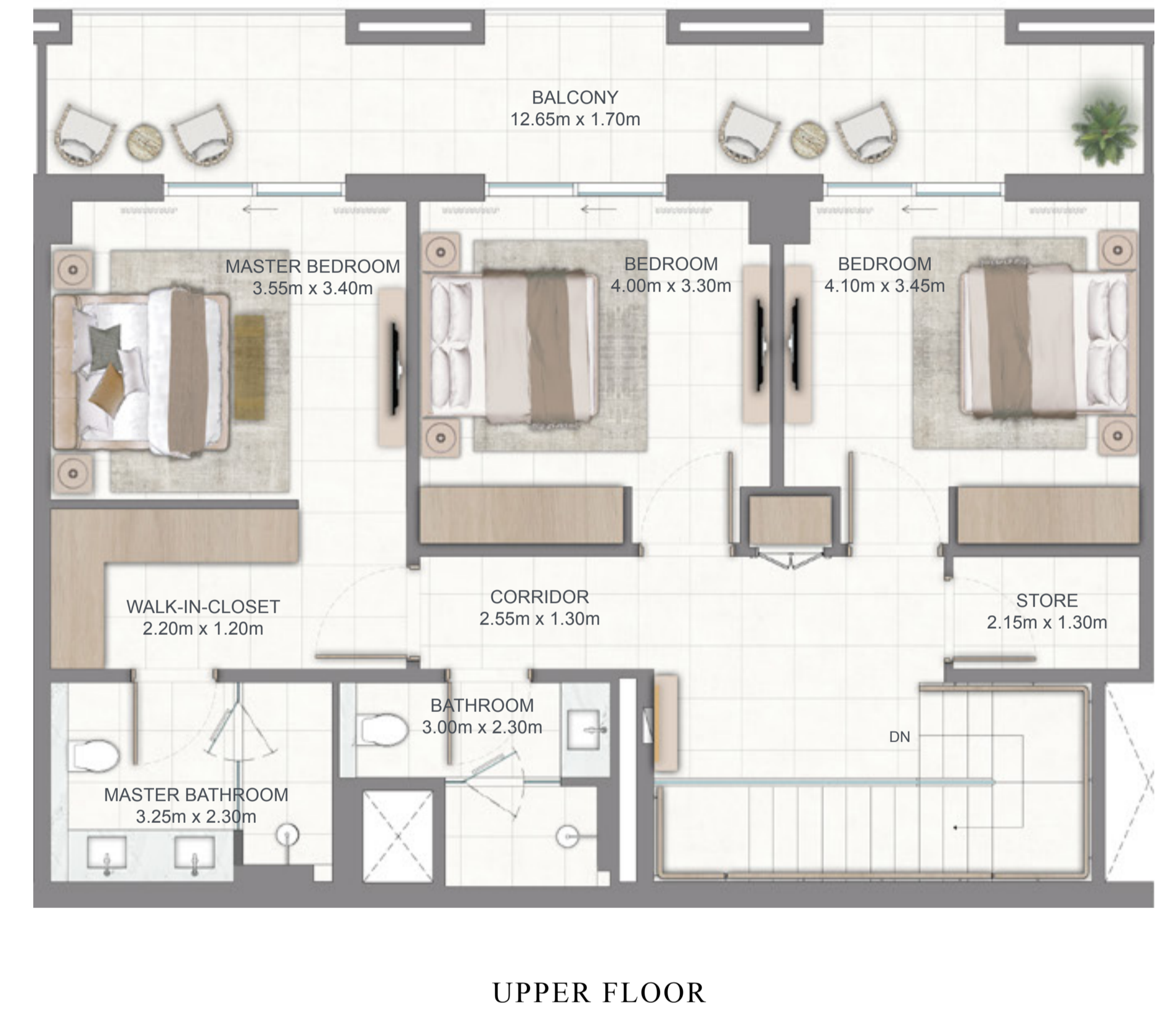

KEY SECTION

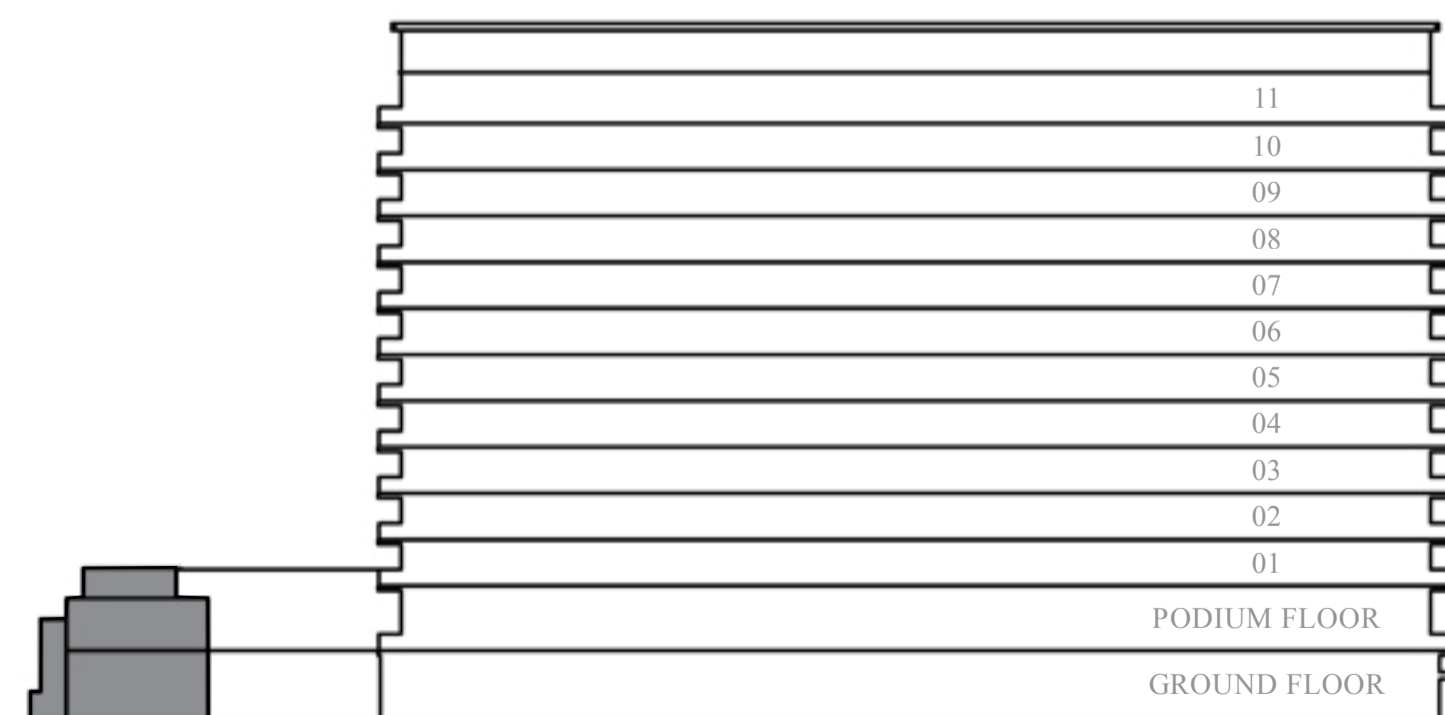

KEY PLANS

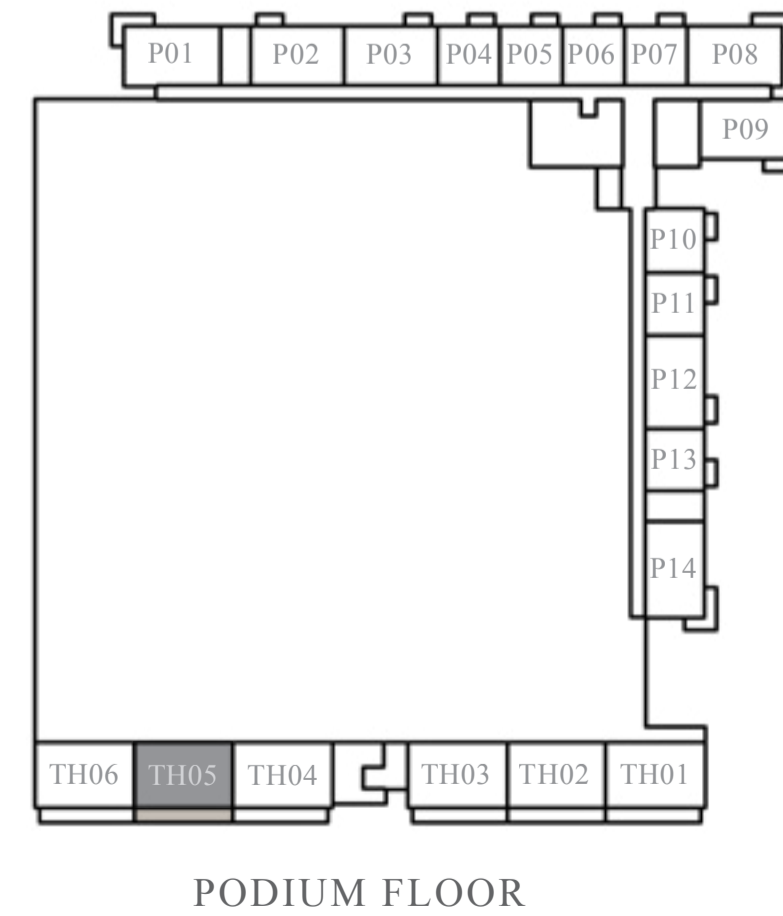
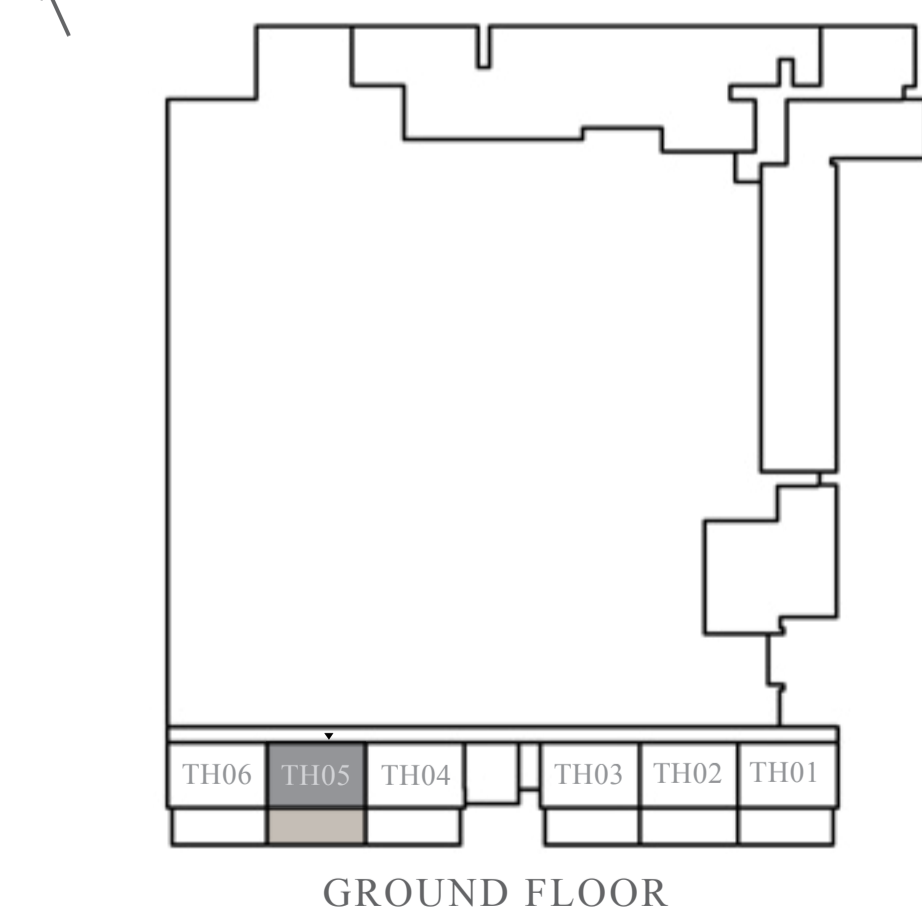

FLOOR PLAN 1. All dimensions are in imperial and metric, and measured from finish to finish excluding construction tolerances. 2. All materials, dimensions, and drawings are approximate only. 3. Information is subject to change without notice, at developer's absolute discretion. 4. Actual area may vary from the stated area. 5. Drawings not to scale. 6. All images used are for illustrative purposes only and do not represent the actual size, features, specifications, fittings, and furnishings. 7. The developer reserves the right to make revisions / alterations, at its absolute discretion, without any liability whatsoever.